

Ancient Indian History, Culture & Archeology(Ph.D. & M.Phil.)

1. The earliest hominid fossil in the Indian Subcontinent was discovered at:
A) Hathnora B) Chirki C) Kupgal D) Utnur
2. The oldest known human burials are associated with:
A) Australopithecus afarensis B) Homo habilis
C) Homo erectus D) Neanderthal man
3. Thermoluminescence method is used to date :
A) Pottery B) Shell C) Bone D) Metal
4. The site of Inamgaon is representative of the :
A) Ahar and Kayatha cultures B) Malwa and Jorwe cultures
C) Savalda and Malwa cultures D) Banas and Jorwe cultures
5. Black -and-Red ware pottery is associated with :
A) Harappan burials B) Neolithic burials
C) Megalithic burials D) Mesolithic burials
6. The geometric microlithic tool- types appeared for the first time in the :
A) Epipalaeolithic culture B) Mesolithic culture
C) Neolithic culture D) Chalcolithic culture
7. Who introduced the concept of typology in archaeology :
A) Pitt Rivers B) R.E.M Wheeler
C) John Marshall D) A. Ghosh
8. Lothal was excavated by :
A) George Dales B) A.N. Dani C) F.A. Khan D) S.R. Rao
9. Control Pits refer to :
A) Test pits B) Square excavation boxes
C) Isolated excavation pits D) Step trenches
10. Pit dwellings are know from which of the following sites :
A) Brahmagiri B) Nagda C) Bhimbetka D) Burzahom
11. Asko Parpola is famous for his work on :
A) Cuneiform Script B) Kharosthi Script
C) Indus Script D) Brahmi Script
12. The 'Great Bath' is situated on the citadel of :
A) Harappa B) Mohanjo daro C) Dholavira D) Lothal
13. Kharosthi Script was deciphered by :
A) William Jones B) James Mill C) Max Muller D) James Prinsep

14. During Skandaguptas reign the weight standard of Gupta gold coins was :
 A) 124 Grains B) 144 Grains C) 100 Grains D) 200 grains
15. The first potin coins were issued by the :
 A) Mauryas B) Guptas C) Kushans D) Satvahanas
16. The Gandhar style of sculpture is found at :
 A) Aihole B) Bhuvaneshwar C) Charsadda D) Mat
17. A stone portrait of King Ashoka was found at :
 A) Mathura B) Texila C) Ropar D) Kanganhalli
18. The Sarnath Buddha image in Dharmachakra mudra belongs to :
 A) Mauryan period B) Shunga period
 C) Kushana period D) Gupta period
19. The Chola period is famous for its :
 A) Stone Sculptures B) Bronze Sculptures
 C) Paintings D) Rock cut caves
20. Lakulisha is an incarnation of :
 A) Mahavira B) Shiva C) Vishnu D) Indra
21. The capital of Anga was :
 A) Champa B) Shravasti C) Ujjain D) Ayodhya
22. Who was referred to as Amitrochates by the Greeks :
 A) Chandragupta Maurya B) Ajatshatru
 C) Bimbisara D) Bindusara
23. Painted Grey ware culture is associated with the use of :
 A) Bronze B) Steel C) Iron D) Lead
24. Rudradaman of the Junagarh inscription was a :
 A) Kshatrapa B) Tribal ruler C) Kushan ruler D) Gupta ruler
25. The name of Kalidasa is mentioned in the :
 A) Aihole inscription B) Belur inscription
 C) Nanaghat inscription D) Allahabad inscription
26. The Eran Stone Boar Inscription refers to :
 A) Toramana B) Harsha C) Huvishka D) Kanishka
27. Which of the following inscriptions refers to the confederacy of Tamil States :
 A) Ashokan Edict XIII B) Hathigumpha
 C) Allahabad Pillar D) Uttaramerur

28. The Parthian king Gondaphares is known from the :
 A) Takht-i-Bahi inscription B) Rabatek inscription
 C) Mathura inscription D) Besnagar inscription
29. Which of the following is a Copper Hoard Culture site:
 A) Hastinapura B) Gungeria C) Inamgaon D) Gumla
30. Anuloma marriage was between:
 A) Man of higher caste and woman of lower caste
 B) Man and woman of same caste
 C) Man of lower caste and woman of higher caste
 D) None of the above
31. Sangam literature mentions an ecological classification of Tamil land (*tinai*) which is:
 A) Twofold B) Threefold C) Fourfold D) Fivefold
32. In Arthashastra the director of agriculture is :
 A) *Sitadhyaksha* B) *Akaradhyaksha*
 C) *Sutradhyaksha* D) *Navadhyaksha*
33. The premier port town of the Cholas was :
 A) Kanchipuram B) Aritkmedu C) Kaveripattinam D) Madurai
34. The S'aka-Kushan occupation of Taxila is represented by :
 A) Bhir Mound B) Sirkap Mound C) Sirsukh Mound D) Mound AB
35. The oldest brick temple is at :
 A) Bhitaraagon B) Rajgir C) Sanchi D) Sirpur
36. The Chaitya hall with a horse-shoe shaped entrance arch is at :
 A) Bhaja B) Kanheri C) Pitalkhora D) Bedsa
37. Which of the following is not a *pancharatha* temple:
 A) Lingraja temple in Bhubaneswar
 B) Raja Rani temple in Bhubaneswar
 C) Jagannath temple in Puri
 D) Raja Rani temple in Khajuraho
38. The *Lilavati* of Bhaskara is a standard text on :
 A) Poetics B) Linguistics C) Mathematics D) Surgery
39. *Saundarananda* was composed by :
 A) Bhase B) Buddhagupta C) Kamandaka D) Asvaghosha
40. Arrentina Ware is associated with the site :
 A) Arikamedu B) Bhita C) Brahmagiri D) Maski

41. During whose stewardship did the Jaina community experience its first major schism:
 A) Indrabhuti Gautama
 B) Sudharma
 C) Bhadrabahu
 D) None of these
42. The title *Vatapikonda* was conferred on :
 A) Narasimhavarman
 B) Pulakesin II
 C) Vikramaditya I
 D) Mahendravarman I
43. The term *bhaga* stands for :
 A) Agricultural tax
 B) Toll tax
 C) Irrigation tax
 D) Municipal tax
44. Which of the following cities was not associated with the Indo-Greeks :
 A) Ai-Khanoum
 B) Taxila
 C) Kokcha
 D) Vidisha
45. *Sarthavahas* were :
 A) Miners
 B) Caravan traders
 C) Weavers
 D) Potters
46. *Vidatha* was:
 A) An assembly
 B) A tribe
 C) A text
 D) An educational center
47. Angkor Wat was originally constructed as a Hindu temple of God :
 A) Shiva
 B) Vishnu
 C) Brahma
 D) Ganesha
48. The first ruler of Kushana dynasty to issue gold coins in India was :
 A) Vima Kadphises
 B) Kanishka
 C) Vasudeve
 D) Kujula Kadphises
49. *Parinibana* is :
 A) Name of a king
 B) Important historical city
 C) Passing away of the Buddha
 D) Animal Species
50. Buddhaghoshas *Visuddhimagga* is a work on :
 A) Mahayana doctrine
 B) Theravada doctrine
 C) Hinayana doctrine
 D) Tantric doctrine

x-x-x

Anthropology(Ph.D.)

- Anthropology is literally the study of
 - Human population patterns
 - Human history
 - Humans
 - The products of human societies
- Which of the following is NOT usually considered one of the four main fields of Anthropology?
 - Prehistoric archaeology
 - Biological anthropology
 - Anthropological linguistics
 - Applied anthropology
- Prosimians, monkeys, apes, and humans are all members of the order
 - Humans
 - Homo sapiens*
 - Primatology
 - Primates
- Mendel's law of independent assortment can be demonstrated by
 - Test cross
 - Monohybrid cross
 - Back cross
 - Dihybrid cross
- Which bone marked with characteristic 'linea aspera'?
 - Ulna
 - Femur
 - Tibia
 - Humerus
- The earliest primates of Palaeocene epoch
 - Apes
 - Lemurs
 - Monkeys
 - Man
- Simian shelf
 - Is a shelf like thickening along the inside of the ape mandible
 - Is a shelf like bony structure in the centre of the femur of man
 - Is a shelf like bony thickness on the upper side of the cranium of ape
 - Is a shelf like bony buttress just above the orbits in apes
- Who described *Gigantopithecus bilaspurensis*
 - Sahni and Chopra 1969
 - Pilbeam and Simons 1970
 - Simons and Chopra 1969
 - Simons and Sahni 1970
- Forehead is well developed and well arched in
 - Gorilla
 - Loris
 - Chimpanzee
 - Man
- '*Systema Naturae*' was written by
 - Darwin
 - Lamarck
 - Weismann
 - Linnaeus
- Who discovered the 'Taung baby'
 - Raymond Dart
 - LSB Leakey
 - Richard Leakey
 - Robert Brown
- Population genetics is the study of
 - Gene pool of main species
 - Gene pool of populations
 - Genetic variations
 - Individual variations

13. Medial malleolus is found in
 A) Cranium B) Femur C) Mandible D) Tibia
14. *Homo heidelbergensis* was discovered in
 A) Germany B) South Africa C) East Africa D) Asia
15. Acheulian culture belongs
 A) South Africa B) East Africa C) Europe D) Asia
16. Baton de Commandment belongs to which cultural phase
 A) Mousterian B) Magdalenian C) Solutran D) Acheulian
17. Venus of Willendorf belongs to
 A) Perigordian B) Solutrean C) Aurignacian D) Mousterian
18. 'Flake culture' is also known as
 A) Lower palaeolithic culture B) Middle palaeolithic culture
 C) Neolithic culture D) Mesolithic culture
19. Langhnaj site belongs to
 A) Lower palaeolithic culture of India B) Middle palaeolithic culture of India
 C) Neolithic culture of India D) Mesolithic culture of India
20. 'Prepared core technique' is also known as
 A) Clactonian technique B) Cylinder hammer technique
 C) Levalloisian technique D) Direct percussion technique
21. The chromosomes which are not associated with sex are known as
 A) Y- chromosomes B) Poly chromosomes
 C) Autosomes D) Polytene chromosomes
22. The terminal end of the chromosome is
 A) Telomere B) Satellite C) Centromere D) Metamere
23. The complete set of genes or genetic material present in a cell or organism is known as
 A) Genetic code B) Genome
 C) Gene amplification D) Transcription
24. 'Gametes are never hybrids', this is a statement of
 A) Law of segregation B) Law of dominance
 C) Law of random fertilization D) Law of independent assortment
25. During mitosis, the chromosomes begin to separate in
 A) Metaphase stage B) Anaphase stage C) Prophase stage D) Telophase stage

26. American anthropologist Clifford Geertz practiced
A) Medical Anthropology B) Political anthropology
C) Symbolic anthropology D) Ecological anthropology
27. "The Division of Labour in Society" was written by
A) EB Tylor B) Margaret Mead
C) Emile Durkheim D) Ruth Benedict
28. Jane Goodall's notable work exists on
A) Cultural anthropology B) Primatology
C) Archaeology D) Human genetics
29. Who among the following has defined culture as "essentially a response to human need"?
A) Radcliff-Brown B) EB Tylor
C) R. Linton D) B. Malinowski
30. Sol Tax was famous for his work on
A) Symbolic anthropology B) Action anthropology
C) Visual anthropology D) Economic anthropology
31. The term "Sankritisation" was coined by
A) L.P. Vidyarthi B) Verrier Elwyn
C) D.P. Mukherjee D) M.N. Srinivas
32. Which among the following is a Matrilineal society
A) Oraon B) Garo C) Bhil D) Baiga
33. The term 'folk society' was first used by
A) Srinivas B) Malinowski C) Tylor D) Redfield
34. A widow marrying the brother of her deceased husband is called:
A) Levirate B) Pratiloma C) Polygamy D) Polygyny
35. Unilineal descent groups are known as
A) Clans B) Tribes C) Caste D) Lineages
36. The culturally established affiliation with one or both the parents is
A) Clan B) Descent C) Tribe D) Caste
37. Pastoralism in an economy is characterized by
A) Killing and eating of animals B) Grazing of animals and using their products
C) Trading of live stocks D) Trading of cereals

49. Hardy Weinberg law is a concept of
- | | |
|---------------------------------|-------------------|
| A) Human Growth and Development | B) Human Genetics |
| C) Population Genetics | D) Human Ecology |
50. HD Sankalia is known for discoveries in
- | | |
|-----------------------|----------------------------|
| A) Palaeoanthropology | B) Human Genetics |
| C) Human Ecology | D) Prehistoric Archaeology |

x-x-x

Bio-Chemistry(Ph.D.)

1. Special structures called telomeres are needed in eukaryotic cells but not in bacteria because eukaryotic cells contain
 - A) Linear chromosomes
 - B) More than one chromosome
 - C) A nucleus
 - D) Circular chromosomes
2. Albinism is a
 - A) Hereditary disease
 - B) Deficiency disease
 - C) Sex-linked disease
 - D) Degenerative disease
3. The regions of chromatin which usually undergo transcription are:
 - A) Nucleosomes
 - B) Heterochromatin
 - C) Euchromatin
 - D) Both euchromatin and heterochromatin
4. In gel filtration chromatography , the separation of proteins is based on-
 - A) Size and charge
 - B) Only charge
 - C) Size and shape
 - D) size and specific affinity
5. If a cell has one chromosome in excess of the normal number of chromosomes present in the nucleus ,it is referred to as –
 - A) Polyploid
 - B) Aneuploid
 - C) Tetraploid
 - D) Haploid
6. If total amount of Guanine and cytosine is 52% in a double stranded DNA, the amount of adenine in this DNA would be-
 - A) 52%
 - B) 24%
 - C) 26%
 - D) 48%
7. You want to purify a recombinant protein by affinity chromatography using a Ni column. You should tag the protein with-
 - A) Histidine
 - B) Biotin
 - C) Glutathione-S-transferase (GST)
 - D) Proline
8. The first trial of gene therapy was for this disorder
 - A) Thalasemia
 - B) Cancer
 - C) Severe combined immunodeficiency disease
 - D) Hemophilia
9. What is antisense technology?
 - A) RNA polymerase producing DNA
 - B) Synthesis of cDNA from mRNA
 - C) Synthesis of lagging DNA strand
 - D) Synthesis of complementary RNA sequence to stop the expression of a specific gene

10. A gene pair hides the effect of another. The phenomenon is:
 A) Epistasis B) Dominance C) Mutation D) None of these
11. Extracellular materials are taken inside the cell by invagination of a segment of plasma membrane by:
 A) Exocytosis B) Endocytosis C) Active transport D) Osmosis
12. Following are the steps in DNA fingerprinting:-
 i) Hybridisation with probe
 ii) Isolation of DNA
 iii) Digestion of DNA with restriction endonucleases
 iv) Detection by autoradiography
 v) Separation of DNA fragments by electrophoresis
 vi) transferring the fragments to synthetic membrane
- Which is the correct order of the steps:-
 A) i,ii,iii,iv,v,vi
 B) v,vi,i,iii,ii,iv
 C) ii,iii,v,vi,i,iv
 D) ii,iii,v,vi,i,iv
13. Components of the respiratory chain are arranged in order of
 A) Increasing redox potential B) Decreasing redox potential
 C) Equivalent redox potential D) In any order of redox potential
14. The Noble prize for chemistry in 2015 is given to , Modrich and Sarkar for their work on-
 A) Signal hypothesis B) Malarial drugs
 C) DNA repair D) Telomeres
15. The anti cancer drug methotrexate is a:
 A) Purine analog B) Pyrimidine analog
 C) Folic acid analog D) Inhibits RNA polymerase
16. An alpha-helical conformation of a globular protein in solution is best determined by which of the following?
 A) Ultraviolet-visible absorbance spectroscopy
 B) Fluorescence spectroscopy
 C) Electron microscopy
 D) Circular dichroism
17. Acetyl CoA, the cytoplasmic substrate for fatty acid synthesis, is formed in mitochondria. The inner mitochondrial membrane is impermeable to acetyl CoA. Which of the following compounds is the form in which the carbon of acetyl CoA is transported to the cytoplasm?
 A) Malate B) Acetate C) Pyruvate D) Citrate

18. Which of the following is NOT characteristic of a eukaryotic enhancer element?
- A) Its activity is independent of its orientation (i.e., the sequence can be inverted without effect)
 - B) Its activity is dependent on its distance from the start site of transcription
 - C) It increases the level of transcription of genes under its control
 - D) It may be found as far as 1 to 2 kilobases from the promoter
19. Choose the appropriate statement regarding Carbamoyl phosphate synthetase I and CPS II
- A) Both use ammonia as a substrate
 - B) CPS I uses ammonia and CPS II uses glutamine as a source of nitrogen
 - C) CPS I is involved in pyrimidine biosynthesis and CPS II in urea cycle
 - D) Both are involved in urea cycle
20. Which statement is not true about transition state analogs-
- A) It fits loosely in active site as compared to the substrate
 - B) It is a potent inhibitor of the enzyme
 - C) It can be used as a hapten to produce catalytic antibodies
 - D) It mimics the reaction intermediate
21. A PCR efficiency of '2' means
- A) 100% efficiency / initial target copies are doubled by the end of the reaction
 - B) 95% efficiency / each target copy is doubled every cycle
 - C) 100% efficiency / each target copy is doubled every cycle
 - D) 95% efficiency / initial target copies are doubled by the end of the reaction
22. Which of the following is an advantage of nested PCR (nPCR)?
- A) Provides a quantitative assessment of initial starting copy number
 - B) Second round PCR products can be a source of laboratory contamination
 - C) Is less time consuming than single round conventional PCR
 - D) Typically has high sensitivity and specificity
23. Assume that you have a cell that is able to complete glycolysis, the citric acid cycle, and the steps of oxidative phosphorylation involving the electron transport chain. However, the ATP synthase in this cell allows passage of H⁺ ions but does not produce ATP. When grown in aerobic conditions, you expect this cell to generate
- A) The same amount of ATP as a cell that was fermenting.
 - B) A little more ATP than a cell that was fermenting.
 - C) A little less ATP than a cell that was fermenting.
 - D) About the same amount of ATP as a cell that was respiring normally under aerobic conditions
24. In vitro experiments using a mutant DNA polymerase led to an increase in error rate from 10^{-6} to 10^{-3} . Which activity is defective in mutant DNA polymerase.
- A) 5'-3' polymerase
 - B) 5'-3' exonuclease
 - C) 3'-5' exonuclease
 - D) 3'-5' polymerase

25. A microfibril of cellulose is composed of about 80 molecules that lie parallel to each other and close together. What type of bond holds the parallel fibers together?
- A) Vanderwaal forces B) Hydrophobic interactions
 C) Ionic interactions D) Hydrogen bonds
26. The initial product of photosynthetic CO₂ fixation in C₃ plants is
- A) Phosphoenol pyruvate B) 3- phosphoglycerate
 C) Glyceraldehyde-3-phosphate D) Dihydroxyacetone phosphate
27. Presence of SNARE proteins has been reported in the membrane of all the following cell organelles except
- A) Endoplasmic reticulum B) Golgi complex
 C) Mitochondria D) Early endosome
28. Membrane carrier proteins differ from membrane channel proteins by which of the following characteristics:-
- A) Carrier proteins do not bind to the transported material while channel proteins do
 B) Carrier proteins are synthesised by free cytoplasmic ribosomes while channel proteins are synthesised on endoplasmic reticulum bound ribosomes
 C) Carrier proteins transport molecules down their electrochemical gradient while channel proteins transport molecules against the electrochemical gradient
 D) Carrier proteins can mediate active transport while channel proteins cannot
29. A mutation deleting an upstream activating sequence for a single gene would be expected to be
- A) cis-dominant B) Trans-dominant
 C) Silent D) Reversible
30. Glycogen phosphorylase is converted to its active form 'a' from its inactive form 'b' by-
- A) Proteolytic cleavage of a peptide fragment from N-terminus
 B) Reversible dimerisation of phosphorylase b triggered by Ca²⁺ ions
 C) Interaction of ATP on the allosteric site of the enzyme
 D) Phosphorylation of a specific Serine residue on each subunit by ATP
31. The length of an α -helix composed of 36 amino acid residues is
- A) 10 Å B) 54 Å C) 27 Å D) 360 Å
32. Kwashiorkor disease is caused by deficiency of the following-
- A) Total calorie intake B) Proteins
 C) Unsaturated fatty acids D) Carbohydrates
33. In vertebrate genes, transcription regulating regions that contain CpG islands are inactivated by which modification
- A) Acetylation B) Farnesylation C) Phosphorylation D) Methylation

34. Eukaryotic cells with DNA damage does not undergo cell cycle until defective DNA is repaired. This phenomenon is called

- A) Check point control
- B) Transcriptional control
- C) Damage control
- D) Anticyclin control

35. A typical curve for an enzyme catalysed reaction is given below. Y- axis depicts the rate of reaction, then X- axis will be represented by -

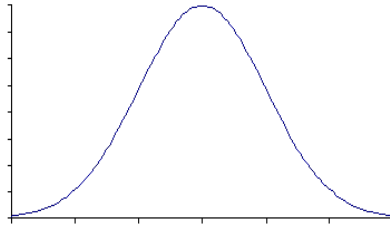

- A) Substrate concentration or pH
- B) Substrate concentration or temperature
- C) Substrate concentration or enzyme concentration
- D) pH or Temperature

36. Choose the incorrect statement about the dielectric constant.

- A) It is unity in vaccum.
- B) It is a measure of the ability of a solvent to keep opposite charges apart.
- C) Non polar substances have a small dielectric constant.
- D) Water has the lowest dielectric constant.

37. The primary action of a steroid hormone is at the level of-

- A) mRNA degradation
- B) Transcription
- C) RNA export from the nucleus
- D) Pre mRNA splicing

38. Which is the most useful experiment that can be done by using a DNA microarray?

- A) Comparing RNA produced under two physiological conditions to understand gene expression
- B) Predicting the presence of specific metabolites in a cell
- C) Evaluating the linkage relationship of two genes
- D) Comparing newly synthesized nuclear RNA with cytoplasmic RNA to locate introns

39. Which of the following statement is true for both Diabetes and starvation?

- A) Blood glucose is elevated
- B) The tissues have higher expression of glucose transporters
- C) Brain switches to ketone bodies for energy production
- D) It is accompanied by high levels of insulin

40. Pick the odd pair out

- A) ErbB- epidermal growth factor receptor
- B) TrkA- nerve growth factor receptor
- C) Ras- guanine nucleotide binding factor with GTPase activity
- D) Fos- platelet derived growth factor

41. Which of the following is not true for thiamine –

- A) Act as a coenzyme for pyruvate dehydrogenase
- B) Milk is a good source
- C) Deficiency causes beri-beri
- D) Deficiency can be assessed by transketolase activity

42. Which of the following is not true for liposomes-

- A) They can be formed by sonicating the suspension of any lipid dissolved in aqueous medium
- B) These are composed of an aqueous compartment enclosed by a lipid layer
- C) These can be used for drug delivery to the target tissues
- D) Molecules can be trapped in the aqueous compartment of lipid vesicles

43. Given below is the energy profile of a given reaction. What will be the energy of activation of the forward reaction. A B.

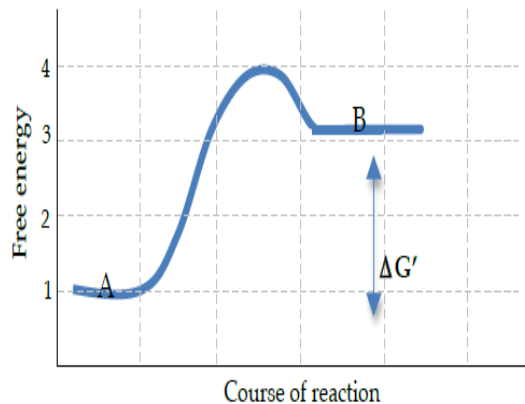

- A) 3
- B) 4
- C) 2
- D) 1

44. In density gradient centrifugation , which of the following DNA molecules will travel the farthest down the tube-

- A) ^{13}C - ^{15}N duplex
- B) ^{15}N - ^{15}N duplex
- C) ^{15}N - ^{14}N duplex
- D) ^{14}N - ^{14}N duplex

45. Which of the following statements is true for phospholipid molecules?
- The polar end of phospholipids would contain carbon and phosphorous and oxygen.
 - The non-polar end of phospholipids would contain almost exclusively carbon and hydrogen.
 - The polar end of phospholipids would form hydrogen bonds with water.
 - The non-polar end of phospholipids associate with the cytoplasm of the cell.
- A) All of these B) i, ii C) ii, iii D) i, ii, iii
46. The main difference between normal and transformed cells are-
- Shorter cell cycle duration
 - Increased apoptosis
 - Immortality and contact inhibition
 - Hyperfunction of tumor suppressor genes
47. Which of the following statements about retrotransposons is correct?
- They contain genes for ribosomal proteins.
 - They transpose via RNA intermediate.
 - They possess a gene for RNA dependent RNA polymerase.
 - They are found only in bacteria.
48. Lipid rafts present in the membrane have different composition than rest of the membrane. On isolation it was found that rafts have cholesterol to sphingolipid ratio of 2:1. Estimated size of raft is 30nm. Surface area of cholesterol is $30A^{02}$ and that of sphingolipids is $60A^{02}$. How many molecules of cholesterol and sphingolipid are present in the lipid raft.
- 30 Cholesterol: 15 sphingolipids
 - 60 Cholesterol: 30 sphingolipids
 - 50 Cholesterol: 25 sphingolipids
 - 15 Cholesterol: 30 sphingolipids
49. All of the following statements apply to transport of macromolecules into and out of the nucleus except
- The protein, Importin differentiates between its cargo and other proteins
 - The energy for nuclear transport is provided by the small Ras family GTPase, Ran
 - Transport occurs through large, proteinaceous structures called nuclear pore complexes
 - A signal peptide containing branched chain amino acids is present on N terminus of nuclear proteins
50. What molecule is used to signal low glucose levels to the Lac operon regulatory system?
- Cyclic AMP
 - Calcium
 - Lactose
 - Pyruvate

x-x-x

(7)

Bio-Physics(Ph.D.)

1. Which is the major force of attraction that stabilizes the 3-D structure of globular protein?
A) Hydrophobic force
B) Hydrogen bond
C) Peptide bond
D) Vander Waals interactions
2. Which of the following is unfavorable for protein folding?
A) Conformational entropy
B) Hydrophobic interaction
C) Van Der Waal's interactions
D) Hydrogen bonding
3. Under the influence of sunlight, x is synthesized in our skin from y, where x and y respectively are
A) Vitamin D, cholesterol
B) Vitamin C, collagen
C) Vitamin A, retinol
D) Vitamin B, starch
4. The bond between first phosphate group attached to sugar molecule in a nucleotide is
A) Phosphoester
B) Phosphodiester
C) Glycosidic
D) Phosphoanhydride
5. In an alpha-helical polypeptide, the backbone hydrogen bonds are between
A) NH of n and CO of n+4 amino acid
B) CO of n and NH of n+3 amino acid
C) CO of n and NH of n+4 amino acid
D) NH of n and CO of n+3 amino acid
6. In electron microscope, as compare to filament, the potential on shield is always
A) Positive
B) Negative
C) Zero
D) Random
7. On excessive administration of digitalis
A) Inversion of P wave take place
B) Elongation of QRS wave take place
C) Inversion of T wave take place
D) None of these
8. Frequency range of beta rhythm in normal EEG
A) 8-13 Hz
B) 18-30 Hz
C) 1-3.5 Hz
D) 4-7 Hz
9. What is the main source of natural background radiation?
A) Electrons
B) X-rays
C) Neutrons
D) Alpha-particles
10. Which photon processes are dominant in the context of diagnostic radiology?
A) Compton scattering and photoelectric effect
B) Photoelectric effect and pair production

- C) Compton scattering and pair production
D) Compton and Rayleigh scattering
11. Magnetic gradient in which direction selects slice thickness in MRI
A) X-axis B) Y-axis C) Z-axis D) All of these
12. What does θ signifies in Bragg's equation: $2d \sin \theta = n\lambda$
A) Angle between incident x-ray and diffracted x-ray
B) Angle between incident x-ray and plane of crystal
C) Angle between incident x-ray and protein molecule
D) Angle between incident x-ray and x-ray grid
13. ^{201}Tl has a decay constant of $9.49 \times 10^{-3} \text{ hr}^{-1}$. Find the activity in becquerels of a sample containing 10^{10} atoms
A) $4.8 \times 10^4 \text{ bq}$ B) $12.6 \times 10^4 \text{ bq}$ C) $2.64 \times 10^4 \text{ bq}$ D) $8.42 \times 10^4 \text{ bq}$
(hint $\text{Act} = \lambda \times \text{number of atoms}$, 9.49×10)
14. An MRS system assumes a nominal frequency of exactly 300 MHz, the approximate resonance frequency for protons in a 7-tesla magnetic field. The peak against which other resonances are compared occurs at 300.004 MHz. Find the chemical shift in parts per million for a peak that occurs at a resonance frequency of 299.998 MHz.
A) 10 ppm B) 20 ppm C) 30 ppm D) 40 ppm
15. In MRI, which pulse sequence will give rise to T1 weighted image
A) Echo planar pulse sequence
B) Spin echo pulse sequence with long TR and long TE
C) Spin echo pulse sequence with long TR and short TE
D) Partial saturation pulse sequence
16. Calculate the distance between parallel planes of cube having miller indices 200
A) $a/2$ B) $a/4$ C) $a/6$ D) $a/8$
17. Calculate the total number of electrons bombarding the target of an x-ray tube operated at 200 mA for 0.1 sec.
A) 200×10^{17} electrons B) 0.5×10^{17} electrons
C) 1.25×10^{17} electrons D) 25×10^{17} electrons
18. Two double stranded DNA samples that are identical with respect to the number of base pairs, but differs significantly in their GC content, can be separated by.
A) Density gradient centrifugation
B) Agarose gel electrophoresis
C) Dialysis
D) Oligo-dT column chromatography

19. Which of the following is not true about RNA?
- A) RNA is chemically more reactive than DNA
 - B) 2'-OH prevents RNA to adopt B-conformation
 - C) RNA was discovered by Hoppe-Seyler
 - D) Feulgen reaction is performed by both DNA and RNA
20. In the cell cycle:
- A) M-phase is both the most complex and the longest phase
 - B) There is a G_0 phase in equilibrium with the G_1 phase
 - C) Quiescent cells cannot be induced to re-enter the cell cycle
 - D) Microtubule spindles form during the S-phase
21. Which of the following modifications leads to protein degradation?
- A) Methylation
 - B) Acetylation
 - C) Phosphorylation
 - D) Ubiquitination
22. The catabolite activating protein (CAP)
- A) Binds to allolactose
 - B) Interacts with the β subunit of RNA polymerase
 - C) Binds the operator sequence of the lac operon
 - D) Causes a binding in the DNA near the start site of transcription
23. Apoptosis or programmed cell death, occurs in all of the following cases except
- A) In virus-infected cells
 - B) In cells damaged by injury
 - C) In cells with potentially cancer-causing mutations
 - D) During the elimination of tissue between the digits in the formation of human fingers
24. At which of the following sites is the partial pressure of carbon dioxide highest?
- A) Exhaled gas
 - B) Alveolar gas
 - C) Systemic arterial blood
 - D) Systemic venous blood
25. In an electrocardiogram, the QRS complex represents the
- A) Depolarisation of the atria
 - B) Repolarisation of the atria
 - C) Depolarisation of the ventricles
 - D) Repolarisation of ventricles
26. Which of the following types of vector would be most suitable for introducing DNA into a human cell?
- A) Plasmid
 - B) Bacteriophage
 - C) Cosmid
 - D) Adenovirus
27. SDS-PAGE does not involve
- A) Separation of proteins based on their molecular weights
 - B) Denaturation of proteins with heat and chemicals
 - C) Application of an electric field to proteins
 - D) Creating a temperature gradient for denaturation of proteins

28. The tertiary structure of protein is detected by
 A) X-ray diffraction/crystallography B) Spectrophotometry
 C) Electrophoresis D) Chromatography
29. T4 polynucleotide kinase is used for
 A) Removes 5'-phosphates from DNA and RNA
 B) Transfers terminal phosphate groups from ATP to 5'-OH groups
 C) Adds homopolymer tails to the 3' end of DNA
 D) Used in mapping studies
30. High doses of antibiotics can destroy the bacterial flora of the large intestine. This can result in impaired:
 A) Absorption of proteins B) Blood coagulation
 C) Bone resorption D) Respiratory control
31. Aspirin, used as a common analgesic, antipyretic and anti-inflammatory agent, inhibits the synthesis of which of the following?
 A) Arachidonic acid B) Prostaglandins
 C) Glucocorticoids D) Histamine
32. During the gluconeogenic conversion of pyruvate into glucose in the liver, all of the following are involved except
 A) Pyruvate carboxylase B) Phosphoenolpyruvate carboxylase
 C) Phosphoenolpyruvatecarboxykinase D) Glucose 6-phosphatase
33. Vitamin B complex is an essential for humans because
 A) It is obtained only from plant sources
 B) It is obtained only from animal sources
 C) It act as cofactor for various metabolic enzymes
 D) It is directly utilized in various metabolic reactions
34. Parts per billion can be represented as
 A) ng/Kg B) $\mu\text{g}/\text{Kg}$ C) $\mu\text{l}/\text{l}$ D) $\mu\text{g}/\text{g}$
35. The outer part of cytoplasm is usually termed as
 A) Plasmasol B) Plasmagel C) Nucleoplasm D) Protoplasm
36. **What is not a toxic form of oxygen?**
 A) Singlet oxygen B) Facultative oxygen
 C) Superoxide free radicals D) Hydroxyl radical
37. Regulation of trp operon by binding of tryptophan to trp repressor is termed as
 A) Repression B) Induction C) Anti termination D) Attenuation

38. The peptide bond in proteins is
- Nonpolar, but rotates to three preferred dihedral angles
 - Planar, but rotates to three preferred dihedral angles
 - Nonpolar and fixed in a trans configuration
 - Planar and usually found in the trans configuration
39. Double chained DNA strand is made radioactive in both its chains. It is allowed to replicate twice in non-radioactive medium. The result would be
- All strands have radioactivity
 - Half the strands have radioactivity
 - Three strands have radioactivity
 - Radioactivity is absent in all strands
40. Which of the following event does not occur during pre tRNA processing?
- 5' end cleavage by the RNase P
 - Addition of poly(A) site
 - Addition of CCA sequence at 3' end
 - Chemical modification of bases
41. Most common type of phospholipids in the cell membrane of nerve cells is
- Phosphatidylcholine
 - Phosphatidylinositol
 - Phosphatidylserine
 - Sphingomyelin
42. Fluorescence recovery after photo bleaching in live cells is used to determine
- Co-localization of proteins
 - Distance between two organelles
 - Diffusion of proteins
 - Nucleic acid compactness
43. Supercoiling of DNA is catalyzed by
- Type I topoisomerases
 - Type II topoisomerases
 - Type III topoisomerases
 - Type IV topoisomerases
44. The cylindrical channels in gap junctions are made of
- Collagen
 - Connexin
 - Fibronectin
 - N-CAM
45. Which part of the ear is responsible for detecting low frequency sound waves?
- Cochlea
 - Eustachian Tube
 - Incus
 - Ear canal
46. Which one of the following is not a pro-inflammatory cytokine:
- IL-1
 - IL-6
 - IL-10
 - TNF- α
47. Antigens in tissues can be localized with fluorescent antibodies using:
- Flow cytometer
 - Autoradiography
 - Electron microscopy
 - Confocal microscopy
48. The Φ and Ψ values for β -sheets lies in
- 1st quadrant of Ramachandran plot
 - 2nd quadrant of Ramachandran plot
 - 3rd quadrant of Ramachandran plot
 - 4th quadrant of Ramachandran plot

49. The homologous recombination is a DNA repair process referred to as recombination repair. Which one of the following statements is incorrect for recombination repair?
- A) DNA polymerase III stalls at the site of dna damage
 - B) DNA polymerase III leaves a gap in the daughter strand
 - C) The gap is filled by recombination between complimentary parent strand homologous to daughter strand and the gapped daughter strand
 - D) Homologous recombination process is catalysed by topoisomerase II
50. Pyrimidine biosynthesis is regulated by
- A) Dihydrofolate reductase
 - B) Thymidylate synthase
 - C) Hexokinase
 - D) Aspartate transcaramoylase

x-x-x

Biotechnology(Ph.D.)

1. NMR spectroscopy is a technique that exploits the magnetic properties of
A) Electrons B) Nuclei C) Positrons D) Photons
2. Beer-Lambert Law states that
A) Absorbance is proportional to both the path length and concentration of the absorbing substance
B) Absorbance is proportional to the log of the concentration of the absorbing substance
C) Absorbance is proportional only to the concentration of the absorbing substance
D) Absorbance is proportional only to the path length of the absorbing substance
3. Which of the following microscopic techniques uses electrons reflected from the surface of a specimen to create image
A) Phase-contrast Microscope
B) Transmission Electron Microscope
C) Scanning Electron Microscope
D) Light Microscope
4. GENSCAN, and CONTRAST are *ab initio* methods for
A) Phylogenetic analysis
B) Multiple Sequence Alignment
C) Gene prediction
D) Primer designing
5. Which of the following gene is responsible for resistance against chilling
A) Glycerol 1 phosphate acyl transferase
B) Polygalactouranase
C) ACC deaminase
D) Sucrose phosphate synthase gene
6. Which tropical fruit crop has been successfully engineered to be protected against a lethal virus?
A) Passion fruit B) Papaya C) Mango D) Lychee
7. Who discovered the recombinant DNA technology
A) HG Khorana
B) JD Watson
C) Sutton and Boveri
D) Stanley Cohen and Herbert Boyer
8. Which of the following is used as a vector in SCID
A) Arbovirus B) Rotavirus C) Parovirus D) Retrovirus

9. Inserting a gene encoding a pathogenic microbe's surface protein into a harmless virus produces a
- A) Piggyback vaccine B) Virulent virus
C) Active disease-causing pathogen D) Pharmaceutical human protein
10. Which of the following is *not* an application of genetic engineering in plants?
- A) Nitrogen fixation B) DNA vaccines
C) resistance to glyphosate D) insecticidal proteins in plants
11. Restriction endonucleases:
- A) Are synthesized by bacteria as part of their defense mechanism
B) Are used for in vitro DNA synthesis
C) Are used in genetic engineering for ligation of two DNA molecules
D) Are present in mammalian cells for degradation of DNA when the cell dies
12. In 3° structure of proteins, folding and shaping is done by
- A) Hydrophobic interactions B) Polar interactions
C) Hydrogen bonding D) Base pairing
13. XY set of chromosomes are termed as
- A) Allosomes B) Autosomes C) Anosomes D) Hetrosomes
14. Ratio between different segregation types arising after sporulation is measure of
- A) Tetratype B) Linkage C) Recombination D) Replication
15. In deamination, amino acid is converted in to
- A) Aldol acid B) Keto acid
C) Hydrochloric acid D) Carboxylic acid
16. Differentiation potential of stem cells specifies
- A) Stochastic differentiation B) Asymmetric replication
C) Potency D) Self renewal
17. Tendency of alleles that are located close together on chromosome to be inherited together during meiosis is
- A) Genetic linkage B) Genetic code C) Inheritance D) Gene expression
18. A process by which a protein structure assumes it's functional shape or conformation is
- A) Denaturing B) Folding C) Synthesis D) Hydrolysis

19. Any favorable movement of solute across membrane is called
A) Active transport
B) Passive transport
C) Solute transport
D) Solvent transport
20. Tunnels which allow specific ions to pass through them are called
A) Selectively permeable tunnels
B) Permeable tunnels
C) Both A and B
D) Channel proteins
21. Number of bases per turn in B-DNA is
A) 10
B) 15
C) 20
D) 25
22. Degeneracy results because there are more codons than
A) Decodable amino acids
B) Encodable amino acids
C) Encodable DNA
D) Encodable RNA
23. Pairing between two nucleotides in RNA that does not follow Watson-Crick base pair rules is called
A) Degeneracy
B) Base pairing
C) Lagervist pairing
D) Wobble pairing
24. Enzyme that makes ATP by chemiosmosis is
A) ATP dehydrogenase
B) Gyrase
C) ATP synthase
D) Dehydrogenase
25. Enzymes that catalyse strand transfer step during recombination are called
A) Recombinases
B) Ttransferases
C) Helicase
D) Gyrase
26. In both meiotic and mitotic cells, recombination between homologous chromosomes is a common mechanism used in
A) DNA replication
B) Transcription
C) DNA repair
D) Translation
27. A steroid which decreases membrane fluidity is
A) Cholesterol
B) Cholic acid
C) Estradiol
D) Progesterone
28. Addition or deletion of a nucleotide base pair involves
A) Point mutation
B) Silent mutation
C) Nonsense mutation
D) Frame shift mutation
29. Respiratory enzymes catalyze
A) Hydrolysis
B) Hydrogenases
C) Redox reactions
D) Polymerase reactions

30. Euchromatin is
A) Lightly packed form of chromatin B) Tightly packed form of chromatin
C) Concentrated form of chromatin D) Elongated form of chromatin
31. Alignment method suitable for aligning closely related sequences is
A) Multiple sequence alignment B) Pairwise alignment
C) Global alignment D) Local alignment
32. The computational method that tries to find the best matching between two molecule, a receptor and ligand is called
A) Molecular matching B) Molecular docking
C) Molecular fitting D) Molecular affinity checking
33. The process of finding relative location of genes on a chromosome is called
A) Gene tracing B) Genome mapping
C) Genome walking D) Chromosome walking
34. A compound that has desirable properties to become a drug is called
A) Lead B) Find C) Fit drug D) Fit compound
35. PRINTS is a software used for
A) detection of genes in the genome sequence
B) detection of tRNA genes
C) prediction of function of new gene
D) identification of functional domain/motifs of proteins
36. In gas chromatography, the basis for separation of the components of the volatile material is the difference in
A) Partition coefficients B) Conductivity
C) Molecular weight D) Molarity
37. Ion exchange chromatography is based on the
A) Electrostatic attractions B) Electrical mobility of ionic species
C) Adsorption chromatography D) Partition chromatography
38. The speed of migration of ions in an electric field depends on
A) Magnitude of charge and mass of molecule
B) Magnitude of charge and shape of molecule
C) Shape and size of the molecule
D) Magnitude of charge, shape and mass of molecule

39. What is the role of SDS in SDS-PAGE
- Protein denaturing and imparting net negative charge
 - Imparting overall negative charge to the protein
 - Imparting equal mass to proteins
 - Protein unfolding and imparting net positive charge
40. Which of the following statements about Western Blotting is correct?
- The detection of a particular protein by Western Blotting relies on the very specific interaction between the protein and its antibody
 - The detection of a particular protein by Western Blotting relies on labelling the protein with a specific dye
 - The detection of a particular protein by Western Blotting relies on labelling the antibody with a specific dye
 - The detection of a particular protein by Western Blotting relies on the denaturation of the protein
41. **Intellectual Property Rights (IPR) protect the use of information and ideas that are**
- of**
- Ethical value
 - Moral value
 - Social value
 - Commercial value
42. **In India, the literary work is protected until**
- Lifetime of author
 - 25 years after the death of author
 - 40 years after the death of author
 - 60 years after the death of author
43. Bern Convention is concerned with
- Trademarks
 - Copyrights
 - Patents
 - Standards
44. Process in which one stem cell develops in to two differentiated daughter cells , another stem cell undergoes mitosis and produces two identical stem cells is called
- Stochastic differentiation
 - Asymmetric replication
 - Potency
 - Self renewal
45. The process that produces a new individual with a known genetic makeup is called _____.
- Regenerative medicine
 - Induced pluripotent stem cells
 - Therapeutic cloning
 - Reproductive cloning
46. Nobel prize in medicine to Tu Youyou was given for his discovery of
- RNAi
 - Autophagy
 - Artemisinin
 - Stem cells from skin
47. Mechanisms for autophagy was discovered by
- Tu Youyo
 - Yoshinori Ohsumi
 - Kornberg
 - Bob Dylan

48. RNA guided genome editing is possible through
- A) RNAi
 - B) CRISPR-Cas
 - C) Activation tagging
 - D) Knock outs
49. Which cell type would not be a direct target for gene therapy
- A) Red blood
 - B) Muscle
 - C) Liver
 - D) Endothelium
50. Which of the following virla vectors are most often used in clinical gene therapy trials?
- A) Lentiviral vectors
 - B) Vaccinia vectors
 - C) Adeno-associated viral vectors
 - D) Adenoviral vectors

x-x-x

Faculty of Business Management & Commerce

1. Research is
 - A) Searching again and again
 - B) Finding solution to any problem
 - C) Working in a scientific way to search for truth of any problem
 - D) None of the above

2. Which of the following is the first step in starting the research process?
 - A) Searching sources of information to locate problem
 - B) Survey of related literature
 - C) Searching for solutions to the problem
 - D) Identification of problem

3. A common test in research demands much priority on
 - A) Reliability
 - B) Usability
 - C) Objectivity
 - D) All of these

4. Action research means
 - A) A longitudinal research
 - B) An applied research
 - C) A research initiated to solve an immediate problem
 - D) A research with socioeconomic objective

5. Which of the following variables cannot be expressed in quantitative terms?
 - A) Numerical Aptitude
 - B) Marital Status
 - C) Socio-economic Status
 - D) Professional Attitude

6. In the process of conducting research 'Formulation of Hypothesis' is followed by
 - A) Statement of Objectives
 - B) Selection of Research Tools
 - C) Analysis of Data
 - D) Collection of Data

7. A research paper is a brief report of research work based on
 - A) Primary Data only
 - B) Secondary Data only
 - C) Both Primary and Secondary Data
 - D) None of the above

8. If a constant 5 is added to each observation of a set, the mean is:
 - A) Increased by 5
 - B) Decreased by 5
 - C) 5 times the original mean
 - D) No change

9. If each observation of a set is multiplying by 10, the mean of the new set of observation:
 - A) Remains the same
 - B) Is 10 times the original mean
 - C) Is one-tenth of the original mean
 - D) Is increased by 10

10. Which of the following is unit-less measure of dispersion?

- A) Standard deviation
- B) Mean deviation
- C) Coefficient of variation
- D) Range

11. Mean deviation is minimum when deviation is taken from

- A) Mean
- B) Median
- C) Mode
- D) Zero

12. The mean and variance of a binomial distribution are 8 and 4, respectively. Then $P(X=1)$ is equal to

- A) $1/2^{12}$
- B) $1/2^4$
- C) $1/2^6$
- D) $1/2^8$

13. t-distribution is used to test

- A) The validity of a postulated value of the population mean
- B) To test the significance of sample correlation coefficient
- C) To test the equality of two population means
- D) All of above

14. Which of the following statement does not hold goods?

- A) An increase the sample size reduces the standard error
- B) An increase in sample size decrease the sampling error
- C) Decrease in sample size results in the reduction of population standard deviation
- D) The precision of an estimate depends on sample size

15. A sample of 25 units from an infinite population with standard deviation 10 results into a total score of 450. The mean of the sampling distribution is

- A) 45
- B) 50
- C) 18
- D) 20

16. The discrepancy between estimates and population parameters is known as

- A) Human error
- B) Enumeration error
- C) Formula error
- D) Sampling error

17. The level of significance is the probability of

- A) Type I error
- B) Type II error
- C) Not committing error
- D) Any of these

18. Whether a test is one-sided or two-sided depends on

- A) Alternative hypothesis
- B) Composite hypothesis
- C) Null hypothesis
- D) Simple hypothesis

19. If the population is more or less homogeneous then which of the following sampling is appropriate

- A) Stratified sampling
- B) Cluster sampling
- C) Quota sampling
- D) Simple random sampling

20. Temperature is measured on

- A) Ordinal Scale
- B) Nominal Scale
- C) Interval Scale
- D) Ratio Scale

21. Size of a household is measured on

- A) Ratio Scale
- B) Nominal Scale
- C) Interval Scale
- D) Ordinal Scale

- 22.** No. of members in a family can be considered as
- A) Continuous variable
 - B) An attribute
 - C) Discrete variable
 - D) None of the above
- 23.** Box and whisker Plot can be used to identify
- A) Symmetry of data
 - B) Outlier
 - C) Skewness
 - D) All of above
- 24.** If the value of kurtosis is positive, then curve is
- A) Mesokurtic
 - B) Platykurtic
 - C) Leptokurtic
 - D) None of these
- 25.** ANOVA stands for
- A) Analysis of non-normal data
 - B) Analysis of variance
 - C) Analysis of covariance
 - D) Analysis of data
- 26.** The value of R^2 always lies between
- A) 0 and 1
 - B) -3 to 3
 - C) -1 to 1
 - D) -1 to 0
- 27.** In multiple regression models, the model validation is based on
- A) High values of R^2
 - B) Close length of prediction intervals
 - C) Small difference between R^2 and adjusted R^2
 - D) All of the above
- 28.** The strength (degree) of the correlation between a set of independent variables X and dependent variable Y is measured by
- A) Coefficient of Correlation
 - B) Coefficient of Determination
 - C) Standard error of estimate
 - D) All of these
- 29.** Person who analyze information system and practicality of computers is classified as
- A) Systems analyst
 - B) Systems manager
 - C) Data manager
 - D) Processing manager
- 30.** If analyst report is approved, analyst helps implementing
- A) New system
 - B) New data
 - C) New terminal
 - D) New terminator
- 31.** In duties of system analyst, analysis of present system includes
- A) Interviewing employees
 - B) Studying documentation
 - C) Preparing a report
 - D) All of these
- 32.** If the mean and standard deviation of series A is 15, 25 and that of series B is 20, 16 then which of the two series is more consistent?
- A) Series A
 - B) Series B
 - C) Series A and Series B are equally consistent
 - D) None of these

33. In case of positive skewed distribution, the extreme values lie in the
 A) Left tail B) Right tail C) Middle D) Anywhere
34. If A and B are two events which have no point in common the event A and B are
 A) Complementary to each other B) Independent
 C) Mutually exclusive D) Dependent
35. The number of possible sample of size n out of N population units with replacement is
 A) ${}^N C_n$ B) n^2 C) N^n D) $n!$
36. Probability of any one sample of size n being drawn out of N units is
 A) $1/N$ B) n/N C) $1/n!$ D) $1/{}^N C_n$
37. Look at this series: 21, 9, 21, 11, 21, 13, 21, ... What number should come next?
 A) 14 B) 15 C) 21 D) 23
38. Look at this series: 3, 4, 7, 8, 11, 12, ... What number should come next?
 A) 7 B) 10 C) 14 D) 15
39. If $a - b = 3$ and $a^2 + b^2 = 29$, then the value of ab is
 A) 10 B) 15 C) 12 D) 18
40. A circle in which sectors represents various quantities is called
 A) Histogram B) Frequency Polygon
 C) Pie Chart D) Component Bar chart
41. A Histogram contains a set of
 A) Adjacent rectangles B) Non Adjacent Rectangles
 C) Adjacent squares D) Adjacent triangles
42. A frequency polygon is a close figure of
 A) Two sided B) Three Sided C) Many sides D) None of these
43. A graph of a cumulative frequency distribution is called
 A) Histogram B) Frequency Polygon
 C) Ogive D) None of these
44. Component bar charts are used when data is divided into
 A) Parts B) Groups C) Circles D) None of these
45. A frequency curve touches x-axis
 A) Always B) Sometimes C) Yes D) No

Study the following table and answer the questions 46 to 50. Expenditures of a Company (in Lakh Rupees) per Annum Over the given Years.

Year	Item of Expenditure				
	Salary	Fuel and Transport	Bonus	Interest on Loans	Taxes
1998	288	98	3.00	23.4	83
1999	342	112	2.52	32.5	108
2000	324	101	3.84	41.6	74
2001	336	133	3.68	36.4	88
2002	420	142	3.96	49.4	98

- 46.** What is the average amount of interest per year which the company had to pay during this period?
A) Rs. 32.43 lakhs
B) Rs. 33.72 lakhs
C) Rs. 34.18 lakhs
D) Rs. 36.66 lakhs
- 47.** The total amount of bonus paid by the company during the given period is approximately what percent of the total amount of salary paid during this period?
A) 0.1%
B) 0.5%
C) 1%
D) 1.25%
- 48.** Total expenditure on all these items in 1998 was approximately what percent of the total expenditure in 2002?
A) 62%
B) 66%
C) 69%
D) 71%
- 49.** The total expenditure of the company over these items during the year 2000 is?
A) Rs. 544.44 lakhs
B) Rs. 501.11 lakhs
C) Rs. 446.46 lakhs
D) Rs. 478.87 lakhs
- 50.** The ratio between the total expenditure on Taxes for all the years and the total expenditure on Fuel and Transport for all the years respectively is approximately?
A) 4:7
B) 10:13
C) 15:18
D) 5:8

x-x-x

Botany

- 1. The type of compound leaves in *Coriander* is:**
A) Unipinnate B) Bipinnate C) Tripinnate D) Decompound
- 2. In Australian *Acacia*, the leaves are modified into:**
A) Cladodes B) Phylloclades C) Phyllodes D) Tendrils
- 3. Raceme of Racemes is also termed as:**
A) Umbel B) Spadix C) Panicle D) Corymb
- 4. The inflorescence in *Euphorbia* species is:**
A) Verticillaster B) Cyathium C) Cymose head D) Capitulum
- 5. Censer mechanism for dispersal of seeds occur in:**
A) Poppy B) *Calotropis* C) *Sonchus* D) *Albizzia*
- 6. The pericarp is not differentiated into epicarp, mesocarp and endocarp in:**
A) Berries B) Drupes C) Pomes D) Coconut
- 7. The example of leaf opposed stem tendrils is:**
A) *Cucurbita* B) Grape-vine C) *Passiflora* D) *Antigonon*
- 8. Katha is extracted from _____ of khair (*Acacia catechu*).**
A) Bark B) Leaves C) Heartwood D) Sapwood
- 9. Pollinia are present in the flowers of:**
A) *Sonchus* B) *Ageratum* C) *Calotropis* D) *Antirrhinum*
- 10. Which plant family store essential oils in oil cells?**
A) Zingiberaceae B) Apiaceae C) Myrtaceae D) Lamiaceae
- 11. The nature of crop grain is:**
A) Aerodynamic B) Hygroscopic C) Wet and dry D) Humid
- 12. The quality of coffee mainly depends upon:**
A) Harvesting B) Processing
C) Physiological maturity D) Ripening
- 13. The literal meaning of word 'Locust' is:**
A) Location B) Area C) Pests D) Plague

14. Leaf roots are found in:

- A) *Sarsinia* B) *Rhynia* C) *Salvinia* D) *Puccinia*

15. A dew drop at the tip of tomato leaves on cool night is formed due to:

- A) Atmospheric water
B) Evaporation of water from stomata
C) Secretion of water from hydathodes
D) Excessive water absorption at the root tips

16. Stone cells are also known as:

- A) Brachysclereids B) Osteosclereids C) Macroschereids D) Trichoblasts

17. The amount of energy required to raise the temperature of a unit mass of a substance by 1°C is called its:

- A) Latent heat B) Heat of vaporization
C) Specific heat D) Endothermic energy

18. In ribose moiety of a ribonucleoside, phosphorylation is possible only at _____ position/s in the furanose ring formation.

- A) One (C5') B) Two (C1', C4')
C) Three (C2', C3' C5') D) Five (C1', C2', C3' C4', C5')

19. The rate of breakdown of carbohydrates _____ by a shift from anaerobic to aerobic condition.

- A) Increases B) Decreases C) Doubles D) No change

20. The conversion of pyruvic acid to acetyl CoA is called:

- A) Fermentation B) Glycolysis
C) Decarboxylation D) Anaerobic respiration

21. The amount of water retained by soil after the drainage of gravitational water is:

- A) Field capacity B) Absorption capacity
C) Drainage capacity D) Capillary water

22. The value of water potential of pure water is:

- A) Zero B) 0.987 atm C) 10^6 dynes m^2 D) 10^8 dynes m^2

23. Ammonia poisoning occurs in temperature sensitive plants at:

- A) Low temperature B) High temperature
C) Moderate temperature D) Low light intensity

24. Opening and closing of flowers represents a kind of:

- A) Autonomic movement
- B) Nutation
- C) Tropic movement
- D) Nastic movement

25. The scutellum of grass embryo is:

- A) Photosynthetic organ
- B) Absorption organ
- C) Reserve food storage organ
- D) Vestigial organ

26. Albuminous seeds are characterized by having:

- A) Endosperm but absence of thick cotyledons
- B) Thick cotyledons but lack of thick endosperm
- C) Thick endosperm and thick cotyledons
- D) Cotyledons but lack of endosperm

27. Which of the following in higher concentration favours growth of paddy crops?

- A) Auxin
- B) GA
- C) ABA
- D) Ethylene

28. In the respiratory chain of electron transport, which one of the following is the terminal cytochrome that reacts with oxygen?

- A) Cytochrome b
- B) Cytochrome b₆
- C) Cytochrome a
- D) Cytochrome a₃

29. Inhibition of enzyme cytochrome oxidase is an example of:

- A) Competitive inhibition
- B) Non-competitive inhibition
- C) Feedback inhibition
- D) Zymogen

30. Path of sugar translocation in dicot plants can be demonstrated by:

- A) Girdling
- B) Grafting
- C) Defoliation
- D) Root pressure

31. Which of the following are important for nitrogen fixation?

- A) Calcium and potassium
- B) Sodium and phosphorus
- C) Magnesium and boron
- D) Iron and molybdenum

32. Statocysts are:

- A) Air-cells
- B) Chlorophyll cells
- C) Fibre-cells
- D) Sensory cells

33. The most efficient precursor of ethylene is:

- A) Adenine
- B) Thiocarbonate
- C) Zeatin
- D) Methionine

- 34. Deficiency of oxygen during mitosis:**
- A) Shortens the cycle period
 B) Extends the cycle period
 C) Has no effect on the process
 D) Cause polyploidy
- 35. Tomato fruit becomes red due to:**
- A) Anthocyanin
 B) Lycopene
 C) Carotin
 D) Xanthophyll
- 36. Carbon cycle involves**
- A) Helium and Hydrogen
 B) Hydrogen and oxygen
 C) Carbon and carbon dioxide
 D) Oxygen and water
- 37. Volicitin molecule plays role in:**
- A) Defense
 B) Tritrophic interactions
 C) Plant reproduction
 D) Allelopathy
- 38. Reactive oxygen species are NOT found in:**
- A) Mitochondria
 B) Peroxisome
 C) Chloroplast
 D) Ribosomes
- 39. The pressure of water vapours nearly _____ for each 10 °C rise in temperature.**
- A) Equals
 B) Doubles
 C) Triples
 D) Reduces to half
- 40. Genetic diversity refers to:**
- A) Intra and inter-specific variations
 B) Intra and inter-generic variations
 C) Intra and inter-varietal variations
 D) Intra and inter-ordeal variations
- 41. Cryogenenic storage of germplasm is done at:**
- A) -4°C
 B) -100°C
 C) -196°C
 D) -273°C
- 42. The first transgenic plant developed for phytoremediation purposes was:**
- A) *Brassica napus*
 B) *Nicotiana tabaccum*
 C) *Arabidopsis thaliana*
 D) *Liriodendron tullpifera*
- 43. The gene which suppresses the action of a gene at other locus is called:**
- A) Lethal
 B) Penetrance
 C) Pleiotropic
 D) Epistatic
- 44. The length of cobs in maize is determined by:**
- A) Single gene
 B) One pair of genes
 C) Two pairs of genes
 D) Environmental factors

45. The starting point in the production of genetically superior seeds of a tree species is the selection of:
- A) Multipurpose Tree Species (MPTS) B) Candidate Plus Trees (CPT)
C) High Yielding Trees (HYT) D) Early Maturing Trees (EMT)
46. Maximum exploitation of heterosis in crop plants is possible only through production of _____ with high degree of heterozygosity.
- A) Sexually reproduced seeds B) F₁ hybrids
C) Bud propagules D) Protoplast culture
47. *Thermus aquaticus* is a source of:
- A) Taq polymerase B) Vent polymerase
C) Both A and B D) Primase enzyme
48. Which cellular organelle is involved in the initiation of intrinsic pathway of apoptosis?
- A) Endoplasmic reticulum B) Lysosomes
C) Mitochondria D) Peroxisomes
49. Which one of the following ions plays an important role in growth of pollen tube?
- A) Calcium B) Chlorine C) Magnesium D) Sulphate
50. Which of the following gene is associated with cold stress tolerance in plants?
- A) FAD7 B) FEP2 C) BADH D) Bjp15

x-x-x

Chemical Engineering(Ph.D) (1077)

1. The value of the momentum correction factor for the viscous flow through a circular pipe is
A) 1.33 B) 1.50 C) 2.0 D) 1.25
2. A Newtonian liquid (ρ = density, μ = viscosity) is flowing with velocity v in a tube of diameter D . let ΔP be the pressure drop across the length L . For a laminar flow, ΔP is proportional to
A) $L \rho v^2/D$ B) $D \rho v^2/L$ C) $L\mu v/D^2$ D) $\mu v/L$
3. Prandtl number is the ratio of :
A) Mass diffusivity to thermal diffusivity.
B) Thermal diffusivity to Momentum diffusivity
C) Thermal diffusivity to mass diffusivity.
D) Momentum diffusivity to Thermal diffusivity
4. The ratio of wall drag to total drag in Stokes's law range is
A) 1 B) 2/3 C) 1/3 D) 4/3
5. Weight of 56 litres of ammonia at N.T.P. is
A) 12.5 gms B) 42.5 gms C) 375.5 gms D) 2500.5 gms
6. Diffusion coefficient in a binary gas mixture at low pressure varies with pressure as
A) P B) P^2 C) $1/P$ D) independent of P
7. C_p - specific heat of a gas at constant pressure, at critical temperature and pressure:
A) Reaches zero B) Reaches 0.34 kcal/ kmol. K
C) Reaches infinity D) Reaches 1 kcal/kmol. K
8. For reversible isobaric process the exponent n in relation $PV^n = \text{constant}$, has the value
A) 1 B) 0 C) ∞ D) 444.4
9. Jigging is a technique by which different particles can be
A) Separated by particle size B) Separated by particle density
C) Separated by particle shape D) Mixed
10. The dew point of a saturated gas phase is equal to
A) Gas temperature B) 0°C
C) 0°C D) Bubble temperature
11. At the inversion point , the joule Thomson coefficient is
A) Positive B) Negative C) Zero D) Infinity
12. Leiden frost point is concerned with
A) Boiling of liquid on hot surface
B) Condensation of vapour on cold surface
C) Concentration of solution by evaporation
D) None of these

13. A system is said to be isopiestic, if there is no
 A) Temperature change B) Pressure change
 C) Volume change D) None of the above
14. On a Mollier chart, the slope of the curve representing a reversible isothermal process is equal to
 A) $T - 1/\beta$ B) $T + 1/\beta$ C) $T - \beta$ D) $T + \beta$
15. In natural convection heat transfer the correlation parameter is
 A) Grashof number B) Eckert number
 C) Graetz number D) Bond number
16. Hardest material of the following is :
 A) Calcite B) Quartz C) Corundum D) Gypsum
17. 200 mesh sieve size corresponds to
 A) 200 microns B) 154 microns C) 74 microns D) 24 microns
18. De-sorption of the adsorbed solute by solvent is called
 A) Reverse osmosis B) Sublimation
 C) Dialysis D) Elusion
19. For an open transfer function $G = k / [(s+1).(s+2).(s+3)]$, the number of poles are :
 A) Zero B) One C) Two D) Three
20. Transfer function of a transportation lag is equal to
 A) $\frac{1}{\tau s + 1}$ B) $e^{-\tau s}$ C) $e^{\tau s}$ D) $(\tau s + 1)$
21. Working principle of filament type optical pyrometer is based on the
 A) Wien's Law B) Seeback effect
 C) Kirchoff's law D) Peltier effect
22. Wax is
 A) Mixture of glycerides
 B) A mixture of esters of polyhydric alcohols except glycerin
 C) Liquid at room temp.
 D) Mixture of glycerides
23. Styrene butadiene rubber is commercially manufactured by
 A) Bulk polymerization B) Suspension polymerization
 C) Solution polymerization D) Emulsion polymerization
24. The work done in non-flow reversible process is given by
 A) $-\int V dp$ B) $\int p dV$ C) $\int V dp$ D) VP

25. For irreversible elementary reaction in parallel

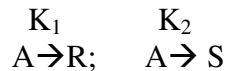

the rate of disappearance of reactant A is given by

- A) $(K_1 - K_2) C_A$ B) $(K_1 + K_2) C_A$ C) $K_1 C_A$ D) $K_2 C_A$

26. For an ideal plug flow reactor the value of the peclet number is

- A) ∞ B) 0 C) 1 D) 10

27. In a mixture of benzene vapor and nitrogen gas at a total pressure of 900 mm Hg. If the absolute humidity of the benzene is 0.2 Kg benzene/ Kg nitrogen, the partial pressure of benzene in mm Hg is

- A) 180 B) 60.3 C) 720 D) 200

28. Which of the following is almost absent in crude petroleum

- A) Olefins B) Mercaptans C) Napthenes D) Cycloparaffins

29. The Triple point of water occurs at 0.00602 atm and

- A) 100.01 °C B) 10.01 °C C) 0.01 °C D) 0.0001 °C

30. The two specific heats C_p and C_v are equal at

- A) 0°C B) 0°K C) 0°F D) 0°R

31. Efficiency of a Carnot Engine working between hot reservoir at temperature T_1 and sink reservoir at temperature T_2 is

- A) $(T_1 - T_2) / T_1$ B) $(T_1 - T_2) / T_2$
C) $T_1 / (T_1 - T_2)$ D) $T_2 / (T_1 - T_2)$

32. Pure carbon is burnt in oxygen. The flue gas analysis is 70% CO_2 , 20% CO and 10% O_2 . The percent excess oxygen used is

- A) 20 B) 12.5 C) 0 D) 10

33. The rate constant of a chemical reaction increases by 100 times when the temperature is increased from 400 K to 500 K. Assuming transition state theory is valid, the value of E/R is

- A) 8987 K B) 8764 K C) 9210 K D) 8621 K

34. Refrigerant Freon-22 is chemically :

- A) Mono chlorodifluoro methane
B) Di chlorodifluoro methane
C) tri chloro mono fluoro methane
D) tri chloro di fluoro methane

35. In a reversible process:

- A) $TdS = dE + dW$
B) $TdS = dE - dW$
C) $TdS = dW - dE$
D) $TdS = dE$

36. Air at 30°C blows over a plate of 50 cm x 75 cm maintained at 260°C. If the convection heat transfer coefficient is 25 W/m².°C, the heat transfer rate is :
- A) 2.156 kW B) 21.56 kW C) 215.6 kW D) 2156 kW
37. A rectangular slab has a surface area of 1.0 m² and is 4 cm thick. It transmits 10 cal/sec.cm² due to a temperature difference between its end faces . If the coefficient of thermal conductivity is 0.8 cal/sec°C and the cooler end is at room temperature 20°C What is the temperature of the other face
- A) 30°C B) 60°C C) 70°C D) 80°C
38. In underdamped second order response overshoot is equal to
- A) (Decay ratio)^{1/2} B) (Decay ratio)¹
 C) (Decay ratio)² D) (Decay ratio)³
39. Solenoid valve works like:
- A) P-D controller B) P-I-D controller
 C) On-off controller D) Proportional controller
40. The conversion X_A and residence time data are collected for zero order liquid phase reaction in a stirred tank reactor. Which of the following will be a straight line
- A) X_A versus τ B) X_A versus ln τ
 C) X_A / (1- X_A) versus τ D) X_A* (1- X_A) versus τ
41. For the gaseous reaction 2A → B, where the feed consists of 50 mol%A and 50 mol% inerts, the expansion factor is
- A) 1 B) -0.5 C) -0.25 D) 0
42. The root locus method , a pole of transfer function G(s) is the value of s for which G(s) approaches
- A) -1 B) 0 C) 1 D) ∞
43. An evaporator while concentrating an aqueous solution from 10 to 40%, solids evaporates 30,000 Kg of water. The amount of solids handled by the steam in Kgs are
- A) 4000 B) 9000 C) 4600 D) 3000
44. When a multistage tray tower uses a minimum reflux ratio it implies
- A) Infinite trays and maximum reboiler heat load
 B) Infinite trays and minimum reboiler heat load
 C) Minimum trays and minimum reboiler heat load
 D) Minimum trays and maximum reboiler heat load
45. For absorbing a sparingly soluble gas in a liquid
- A) Gas side mass transfer coefficient should be increased
 B) Liquid side mass transfer coefficient should be increased
 C) Liquid side mass transfer coefficient should be decreased
 D) Mass transfer coefficient must be kept consistent

46. The theoretical minimum work required to separate one mole of a liquid mixture at 1 atm, containing 50 mol% each of n- heptane and n – octane, into pure compounds each at 1 atm is
- A) $- 2 RT \ln 0.5$
B) $- RT \ln 0.5$
C) $0.5 RT$
D) $2 RT$
47. Fluidized beds are formed when
- A) Gravity force is less than fluid friction
B) Fluid friction is zero
C) Pressure forces equal gravity forces
D) Sum of fluid friction and pressure forces is equal and opposite to gravity forces
48. A counter flow heat exchanger is used to heat water from 20°C to 80°C by using hot exhaust gas entering at 140°C and leaving at 80°C . The log mean temperature difference for the heat exchanger is
- A) 80°C
B) 60°C
C) 110°C
D) None of the above
49. An investment of Rs 100 lakhs is to be made for construction of plant which will take two years to start production. The annual profit from operation of the plant is Rs 20 lakhs. What will be the payback time
- A) 5 years
B) 7 years
C) 12 years
D) 10 years
50. For a first order chemical reaction in a porous catalyst, the thiele modulus is 10. The effectiveness factor is approximately equal to
- A) 1
B) 0.1
C) 0.15
D) 0

x-x-x

Chemistry(Ph.D.) (1077)

1. Among the following ions which one has the highest paramagnetism?
(A) $[\text{Zn}(\text{H}_2\text{O})_6]^{2+}$ (B) $[\text{Cu}(\text{H}_2\text{O})_6]^{2+}$
(C) $[\text{Fe}(\text{H}_2\text{O})_6]^{2+}$ (D) $[\text{Cr}(\text{H}_2\text{O})_6]^{3+}$
2. In $[\text{NiF}_6]^{4-}$, $[\text{FeF}_6]^{3-}$, $[\text{TiF}_6]^{2-}$ and $[\text{CrF}_2]$
(A) All shows JahnTaller distortion
(B) $[\text{NiF}_6]^{4-}$ and $[\text{TiF}_6]^{2-}$ shows JahnTaller distortion
(C) Only $[\text{CrF}_2]$ shows JahnTaller distortion
(D) None of the above
3. Which of the following complex ions shows minimum intensity of absorption in UV-Visible region?
(A) $[\text{Cr}(\text{H}_2\text{O})_6]^{2+}$ (B) $[\text{Mn}(\text{H}_2\text{O})_6]^{2+}$
(C) $[\text{V}(\text{H}_2\text{O})_6]^{2+}$ (D) $[\text{Co}(\text{H}_2\text{O})_6]^{2+}$
4. The ESR spectrum of naphthalene radical anion consists of:
(A) 15 lines (B) 25 lines (C) 30 lines (D) 40 lines
5. The g value for the benzene radical anion is 2.0025. At what field would you search for resonance in a spectrometer operation at 9.302 GHz?
(A) 0.432 T (B) 0.332 T (C) 0.872 T (D) 0.243 T
6. Melting point of NaCl, NaBr, NaI and NaF will be in order:
(A) $\text{NaCl} < \text{NaI} < \text{NaF} < \text{NaBr}$ (B) $\text{NaBr} < \text{NaF} < \text{NaCl} < \text{NaI}$
(C) $\text{NaI} < \text{NaBr} < \text{NaCl} < \text{NaF}$ (D) $\text{NaF} < \text{NaCl} < \text{NaBr} < \text{NaI}$
7. Which is maximum hydrated?
(A) SiCl_4 (B) AlCl_3 (C) MgCl_2 (D) NaCl
8. Of the following mixtures of two pure acids the strongest acid will be:
(A) $\text{HNO}_3 + \text{H}_2\text{SO}_4$ (B) $\text{H}_3\text{BO}_3 + \text{H}_2\text{SO}_4$
(C) $\text{HClO}_4 + \text{H}_2\text{SO}_4$ (D) $\text{KHSO}_4 + \text{H}_2\text{SO}_4$
9. CO_2 cannot be obtained by heating:
(A) Na_2CO_3 (B) Li_2CO_3 (C) CaCO_3 (D) $\text{Ca}(\text{HCO}_3)_2$
10. Solution of Na metal in liquid NH_3 , is a strong reductant due to the presence of:
(A) Sodium ion (B) Solvated electrons
(C) Sodium amide (D) Sodium hydride
11. B H B bridge in B_2H_6 is formed by sharing of:
(A) 2 electrons (B) 4 electrons (C) 1 electrons (D) 3 electrons

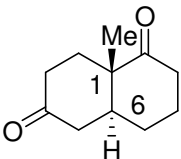
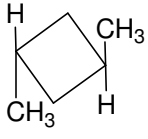
12. PI_3 upon hydrolysis gives:
- (A) Monobasic acid and dibasic acid (B) Monobasic acid and tribasic acid
(C) Monobasic acid and a salt (D) Dibasic acid and tribasic acid
13. Which one of the following is sp^3d hybridised:
- (A) XeO_3 (B) XeOF_2 (C) XeOF_4 (D) XeF_4
14. The square pyramidal molecular shape is adopted by:
- (A) SOF_4 (B) PF_5 (C) XeOF_4 (D) ScOCl_4
15. From molecular orbital configuration of CO and NO^+ , we would predict:
- (A) Both have a bond order of 3
(B) Both are paramagnetic
(C) Both will readily loss an electron to form CO^+ or NO^{2+}
(D) Both CO and NO^+ should not exist
16. Indicate the organometallic complex that obeys the EAN rule:
- (A) $\text{Ni}(\pi\text{-C}_5\text{H}_5)_2$ (B) $(\text{C}_2\text{H}_5)\text{W}(\text{CO})_2(\pi\text{-C}_5\text{H}_5)$
(C) $\text{Co}(\text{C}_6\text{H}_6)$ (D) $(\pi\text{-C}_5\text{H}_5)_2\text{TiCl}_2$
17. The trivalent ion having largest size is:
- (A) La (B) Ti (C) Zr (D) Hf
18. The absolute configuration of two chiral centers (C-1, C-6) present in compound given below is:
- 
- (A) 1R, 6R (B) 1R, 6S (C) 1S, 6R (D) 1S, 6S
19. The relation between compound X and Y is:
- 

X

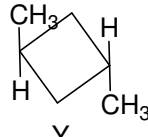

Y
- (A) Achiral identical mirror image (B) Enantiomers
(C) Meso structure (D) Racemic mixture
20. Singlet and triplet carbene can be identified by reaction with:
- (A) Alkene (B) Electrophile (C) cis or trans Alkene (D) Benzyne

21. The relationship between two compounds given below are:

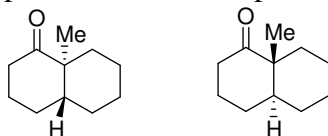

- (A) Enantiomers (B) Diastereomers
(C) Meso (D) Regioisomers

22. Which of the following compound is aromatic in nature?

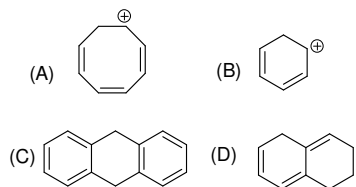

23. Alkyl halide with halogen at bridge head are inert to nucleophilic substitution through S_N1 mechanism is due to

- (A) Steric strain
(B) Poor leaving ability of halogen at bridge head
(C) Rigid geometry
(D) Formation of carbocation at bridge head is not possible

24. Which rule prevent the formation of double bond at bridge head?

- (A) Bredts rule (B) Crams rule
(C) Hofmann rule (D) Saytzeff Rule

25. The major product formed in the following reaction sequence is:

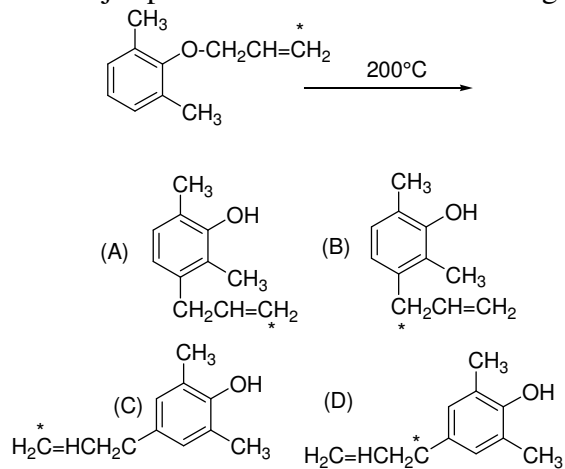

26. The selective reduction of α,β -unsaturated ketones to α,β -unsaturated alcohols can be achieved by:

- (A) NaBH_4 (B) $\text{BH}_3 \cdot \text{SMe}_2$
(C) LiAlH_4 (D) $\text{NaBH}_4 / \text{CeCl}_3$

27. The most suitable reagent for carry out the transformation given below:

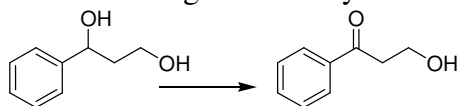

- (A) Jones reagent
(B) Manganese dioxide
(C) Lead tetraacetate
(D) Swarn's reagent

28. The most suitable reagent for carry out the transformation given below:

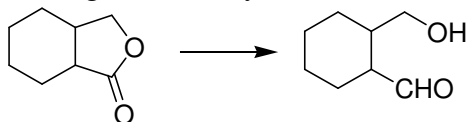

- (A) NaBH₄
(B) BH₃. SMe₂
(C) LiAlH₄
(D) DIBAL-H

29. Cope rearrangement is an example of:

- (A) [2,3] Sigmatropic shift
(B) [2,4] Sigmatropic shift
(C) [3,3] Sigmatropic shift
(D) [1,3] Sigmatropic shift

30. The following reaction is an example of:

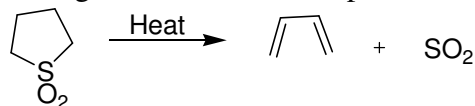

- (A) Electrocyclic reaction
(B) Anti cycloaddition reaction
(C) Sigmatropic rearrangement
(D) Cheletropic reaction

31. tert.-Butoxycarbonyl group i.e (CH₃)₃COCO- protected amine can be deprotected by:

- (A) 10% KOH solution
(B) CF₃COOH
(C) Lithium aluminum hydride
(D) Diboran

32. Aldehydes can be protected as acetals by reaction of aldehydes with excess of alcohol in presence of:

- (A) 10% KOH solution
(B) 10% HCl
(C) HCl gas
(D) 10% H₂SO₄

33. Predict the structure of compound with molecular formula C₈H₁₆. ¹H NMR of this compound exhibit only one signal at δ (1.29, 16H). The compound is:

- (A) Cyclooctane
(B) Methyl cycloheptane
(C) 1,2-Dimethyl cyclohexane
(D) 1,2,3-Trimethyl cyclopentane

34. In the mass spectrum of 1, 2-dibromoethane, approximate ratio of peaks at m/z values 186(M⁺), 188(M⁺+2), 190 (M⁺+4) will be:

- (A) 6:1:4
(B) 9:6:1
(C) 1:2:1
(D) 4:2:3

35. X-rays with wavelength 1.54 Å are reflected from the (1 1 0) planes of a cubic crystal with unit cell a = 6 Å. The Bragg angle, θ, for first order of reflection i.e. n = 1 would be

- (A) 10.46°
(B) 21.30°
(C) 33.01°
(D) 46.59°

36. A first order reaction is found to have a rate constant, $k = 5.5 \times 10^{-14} \text{ sec}^{-1}$. The half-life of the reaction is:
- (A) $1.81 \times 10^{14} \text{ sec}$ (B) $1.26 \times 10^{13} \text{ sec}$
 (C) $1.81 \times 10^{13} \text{ sec}$ (D) $1.26 \times 10^{14} \text{ sec}$
37. Variation of chemical potential with pressure results
- (A) Partial molar entropy (B) Partial molar volume
 (C) Partial molar enthalpy (D) Partial molar internal energy
38. The heat of reaction $\frac{1}{2} \text{H}_2 + \frac{1}{2} \text{Cl}_2 \rightarrow \text{HCl}$ at 27°C is -22.1 kcal . Calculate the heat of reaction at 77°C . The molar heat capacities at constant pressure at 27°C for hydrogen, chlorine and HCl are 6.82, 7.70 and $6.80 \text{ cal mol}^{-1}$ respectively.
- (A) -27.832 kcal (B) -26.231 kcal
 (C) -22.123 kcal (D) -21.978 kcal
39. Activity coefficients calculated using Debye-Huckel law are always
- (A) Less than zero (B) Equal to one
 (C) Less than one (D) Greater than one
40. If the wave function of a particle trapped in space between $x = 0$ and $x = L$ is given by $\Psi(x) = A \sin(2\Pi x/L)$, where A is a constant. For which value(s) of x will the probability of the finding of particle be maximum
- (A) $L/2$ (B) $L/4$
 (C) $L/6$ and $L/3$ (D) $L/4$ and $3L/4$
41. The protecting power of lyophilic colloidal sol is expressed in terms of
- (A) Critical micelle concentration (B) Oxidation number
 (C) Coagulation value (D) Gold number
42. Which of the following methods gives the number average molecular weight of a polymer?
- (A) Light scattering method (B) Viscosity method
 (C) Sedimentation equilibrium method (D) Sedimentation velocity method
43. SiF_4 , BF_4^- belongs to which point group?
- (A) O_h (B) T_d (C) C_{2v} , D_{2h} (D) D_{2h} , C_{2v}
44. The function of alum used for purification of water is to
- (A) Coagulate the sol particles (B) Disperse the sol particles
 (C) Emulsify the sol particles (D) Absorb the sol particles
45. If we operate a Carnot's engine between the freezing point and boiling point of water, what will be the efficiency of that engine?
- (A) 100 % (B) 0 % (C) 27 % (D) 73%

46. If the molar conductance at infinite dilution of NaCl, HCl and CH₃COONa are 126.4, 425.9 and 91.0 S cm² mol⁻¹ respectively. The molar conductance at infinite dilution for Acetic acid is:
- (A) 390.5 S cm² mol⁻¹ (B) 300.9 S cm² mol⁻¹
 (C) 290.5 S cm² mol⁻¹ (D) 200.9 S cm² mol⁻¹
47. The Tafel equation is an equation in [electrochemical kinetics](#) relating
- (A) The rate of an [electrochemical](#) reaction to the concentration
 (B) Cell potential to concentration
 (C) The rate of diffusion current to the [potential](#)
 (D) The rate of an [electrochemical](#) reaction to the [overpotential](#)
48. The pure rotational spectrum of CO consists of a series of equally spaced lines separated by 3.84235 cm⁻¹. The atomic masses are: ¹²C = 19.92168 x 10⁻²⁷ kg and ¹⁶O = 26.56136 x 10⁻²⁷ kg. The internuclear distance of the molecule is
- (A) 2.312 Å (B) 1.456 Å (C) 1.131 Å (D) 1.921 Å
49. What is the equilibrium constant for the reaction given below at 298 K, if E_{cell} = 1.10 V at 298 K?
- $$\text{Zn}^{2+}(\text{aq}) + \text{Cu}(\text{s}) \rightarrow \text{Zn}(\text{s}) + \text{Cu}^{2+}(\text{aq})$$
- (A) e^{57.8} (B) 10^{57.8} (C) 10^{85.7} (D) e^{85.7}
50. In a solid “AB” having the NaCl structure, “A” atoms occupy the corners of the cubic unit cell. If all the face centered atoms along one of the axes are removed, then the resultant stoichiometry of the solid is:
- (A) AB₂ (B) A₃B₄ (C) A₄B₃ (D) A₂B

x-x-x

14. Flow in pipes is turbulent if Reynold's number is
 A) Less than 2100
 B) Greater than 3000
 C) Between 2100 & 3000
 D) None of these
15. A floating body attains stable equilibrium if the meta-centre is
 A) At the Centroid
 B) Above the Centroid
 C) Below The Centroid
 D) Anywhere
16. Offset Rods are used to measure
 A) Short Offsets
 B) Ranging
 C) Contouring
 D) None of these
17. D.O. Concentration falls down to zero anywhere in a natural drain, it indicates
 A) Zone of Degradation
 B) Zone of active decomposition
 C) Zone of Recovery
 D) Zone of clear Water
18. Average Temperature of Sewage in India is
 A) 10°C
 B) 20°C
 C) 15°C
 D) 25°C
19. Standard BOD of Water is taken for
 A) 1 Day
 B) 2 Days
 C) 3 Days
 D) 5 Days
20. The Detention time of a settling tank may be defined as the time required for
 A) A Particle to travel along its length
 B) A particle to travel from top surface to bottom sludge Zone
 C) The Flow of Sewage to fill the tank.
 D) None of these
21. Cohesionless soil is
 A) Sand
 B) Silt
 C) Clay
 D) Clay & Silt
22. The specific gravity and Void Ratio of a soil sample are 'G' and 'e' respectively. The critical Hydraulic gradient 'I' is given by
 A) $G - 1/1 + e$
 B) $G + 1/1 + e$
 C) $G + 1/G - e$
 D) $1 - G/1 + e$
23. The coefficient of active earth Pressure K_a is $1/3$, then the coefficient of passive earth Pressure K_p shall be
 A) $1/3$
 B) $2/3$
 C) 3
 D) $3/2$
24. In Concrete Roads, Camber provided is
 A) 1 in 20 to 1 in 24
 B) 1 in 36 to 1 in 48
 C) 1 in 60 to 1 in 72
 D) 1 in 48 to 1 in 60
25. The minimum grade of concrete for construction under sea water is
 A) M20
 B) M30
 C) M35
 D) M15
26. For the construction of RCC slabs, beams, columns and walls, the grade of concrete mix used is
 A) 1:3:6
 B) 1:1.5:3
 C) 1:2:4
 D) 1:1:2

27. Expansion joints are provided if length of concrete structure exceeds
 A) 50m B) 45m C) 35m D) 40m
28. The shuttering of a hall measuring 4mx5m can be removed after
 A) 5days B)7days C) 14days D) 21 days.
29. Gypsum to the cement is added for
 A) Colour B) Strength
 C) Controlling Setting time D) None of these
30. The Max. Shear Stress q_{\max} in a rectangular beam section is
 A) $1.25q_{\max}$ B) $1.5q_{\max}$ C) $2q_{\max}$ D) $2.5q_{\max}$
31. If the diameter of a reinforcing bar is 'd', the anchorage value of hook shall be
 A) 4d B) 8d C) 12d D) 16d
32. A couple produces
 A) Translatory motion
 B) Rotational Motion
 C) Combined Translatory and Rotational Motion
 D) None of these
33. A flat slab is supported
 A) On Beams
 B) On columns
 C) On beams and Columns
 D) On columns monolithically built with slab
34. As the percentage of steel in beams increase
 A) The depth of NA decreases B) The depth of NA increases
 C) Lever Arm decreases D) Lever Arm increases
35. The Shear reinforcement in RCC is provided to resist
 A) Vertical Stress B) Horizontal Shear
 C) Diagonal Compression D) Diagonal Tension
36. Poisson's Ratio for steel within elastic limit ranges from
 A) 0.15-0.20 B) 0.25-0.33 C) 0.33-0.35 D) 0.45-0.50
37. For simply supported beam, maximum permissible deflection is
 A) 1/325 of the span B) 1/425 of the span
 C) 1/150 of the span D) 1/36 of the span
38. The field capacity of the soils depends upon
 A) Capillary tension in soils B) Porosity of soils
 C) Both A & B D) None
39. The difference in level between the top of a bank and FSL of water in canal is called
 A) Berm B) Free Board
 C) Height of bank D) None

40. A Viaduct is a bridge constructed over a
 A) Valley B) River C) Hillock D) None
41. The last reading in Levelling operation is always a
 A) Backsight B) Foresight
 C) Intermediate Sight D) All the above
42. Fat Lime Sets in the Presence of
 A) Carbon Dioxide B) Oxygen
 C) Sulphur Dioxide D) All of these
43. Cement possesses the unique property of
 A) Settling B) Decrease in Strength with age
 C) Increase in Strength with age D) None of these
44. The limiting Gradient recommended in the plain area is
 A) 1 in 10 B) 1 in 15 C) 1 in 100 D) 1 in 20
45. Density required in Embankment up to 3m height is
 A) 1.55gm/cc B) 1.67gm/cc C) 1.44gm/cc D) 1.77gm/cc
46. Index Map Shows the
 A) Exact Topography of the area B) General Topography of the area
 C) Contour map of the area D) None of these
47. Abrasion test is conducted to find the
 A) Hardness of aggregates B) Impact value
 C) Toughness D) Permeability
48. Sheep Footed rollers are suitable for the compaction of
 A) Sandy Soils B) Clayey Soils C) Gravels D) None of these
49. The position occupied by the centre line of a road is called
 A) Super elevation B) Road Alignment
 C) Camber D) Shoulder
50. The traffic signs indicating Prohibitions are known as
 A) Warning Signs B) Prohibitory Signs
 C) Mandatory Signs D) None of these

x-x-x

Civil Engineering(Ph.D.) (1077)

1. The fineness of cement is tested by
A) Air-content test
B) Air-permeability Method
C) Le-Chatelier apparatus
D) Vicat's apparatus
2. Ultimate strength of cement is influenced by which one of the following?
A) Tricalcium silicate
B) Dicalcium silicate
C) Tricalcium aluminate
D) Tetracalcium aluminoferrite
3. The maximum bulking of sand is likely to occur at a moisture content of
A) 5%
B) 8%
C) 11%
D) 14%
4. One of the main demerits in using the lime mortar is that it
A) Is not durable
B) Does not set quickly
C) Swells
D) Is plastic
5. If in a concrete mix the fineness modulus of coarse aggregate is 7.6, the fineness modulus of fine aggregate is 2.8 and the economical value of the fineness modulus of combined aggregate is 6.4, then the proportion of fine aggregate is
A) 25%
B) 33.33%
C) 50%
D) 66.67%
6. The optimum number of revolutions over which concrete is required to be mixed in a mixer machine is
A) 10
B) 20
C) 50
D) 100
7. To make one cubic meter of 1:2:4 by volume concrete, the volume of coarse aggregates required is
A) 0.98 m^3
B) 0.88 m^3
C) 0.78 m^3
D) 0.68 m^3
8. What is the representative geometric mean size of an aggregate sample if its fineness modulus is 3.0?
A) $150 \mu\text{m}$
B) $300 \mu\text{m}$
C) $600 \mu\text{m}$
D) $75 \mu\text{m}$
9. A bar of diameter 30mm is subjected to a tensile load such that the measured extension on a gauge length of 200 mm is 0.09 mm and change in diameter is 0.0045 mm. The Poisson's ratio will be
A) $\frac{1}{4}$
B) $\frac{1}{3}$
C) $\frac{1}{5}$
D) $\frac{1}{6}$
10. The length, coefficient of thermal expansion and Young's modulus of bar A are twice that of bar B. If the temperature of both bars is increased by the same amount while preventing any expansion, then the ratio of stress developed in bar A to that in bar B will be
A) 2
B) 4
C) 8
D) 16
11. A given material has Young's modulus E, modulus of rigidity G and Poisson's ratio 0.25. The ratio of Young's modulus to modulus of rigidity of this material is
A) 3.75
B) 3.00
C) 2.50
D) 1.50

12. A member having length L , cross-sectional area A and modulus of elasticity E is subjected to an axial load W . The strain energy stored in this member is
 A) $\frac{WL^2}{AE}$ B) $\frac{WL^2}{2AE}$ C) $\frac{W^2L}{2AE}$ D) $\frac{W^2L}{AE}$
13. A mild steel rod tapers uniformly from 30 mm diameter to 12 mm diameter in a length of 300 mm. The rod is subjected to an axial load of 12 kN. $E=2 \times 10^5 \text{ N/mm}^2$. What is the extension of the rod in mm?
 A) $\frac{4\pi}{5}$ B) $\frac{2}{5\pi}$ C) $\frac{\pi}{5}$ D) $\frac{1}{5\pi}$
14. A simply supported beam AB is subjected to a concentrated load at C, the centre of the span. The area of the Shear Force diagram from A to C will give
 A) Bending Moment at C
 B) Load at C
 C) Shear Force at C
 D) Difference between BM values at A and B
15. The principal strains at a point are $+800 \times 10^{-6} \text{ cm/cm}$, $+400 \times 10^{-6} \text{ cm/cm}$ and $-1200 \times 10^{-6} \text{ cm/cm}$. The volumetric strain is equal to
 A) $+1200 \times 10^{-6} \text{ cm/cm}$ B) $+800 \times 10^{-6} \text{ cm/cm}$
 C) $-1200 \times 10^{-6} \text{ cm/cm}$ D) Zero
16. If the hinged end of a propped cantilever of span L settles by an amount δ , then the rotation of the hinged end will be
 A) $\frac{\delta}{L}$ B) $\frac{2\delta}{L}$ C) $\frac{3\delta}{2L}$ D) $\frac{4\delta}{3L}$
17. If the area under the shear curve for a beam between the two points X_1 and X_2 is k , then difference between the moments at the two points X_1 and X_2 will be equal to
 A) k B) $2k$ C) $k/2$ D) k^2
18. A beam has the same section throughout its length with $I=1 \times 10^8 \text{ mm}^4$. It is subjected to a uniform BM = 40 kN-m, $E = 2 \times 10^5 \text{ N/mm}^2$. What is the radius of curvature of the circle into which the beam will bend in the form of an arch of a circle?
 A) 1000 m B) 400 m C) 350 m D) 500 m
19. Two beams carrying identical loads, simply supported are having same depth but beam A has double the width as compared to that of beam B. The ratio of the strength of beam A to that of beam B is
 A) $\frac{1}{2}$ B) $\frac{1}{4}$ C) 2 D) 4
20. The ratio of tensile stress developed in the wall of a boiler in the longitudinal direction to the tensile stress in the circumferential direction due to an internal pressure is
 A) 4 B) 2 C) $\frac{1}{4}$ D) $\frac{1}{2}$
21. In the limit state approach, spacing of main reinforcement controls primarily
 A) Cracking B) Deflection C) Durability D) Collapse

22. Drops are provided in flat slabs to resist
 A) Bending moment B) Thrust C) Shear D) Torsion
23. A reinforced concrete beam of 10m effective span and 1 m effective depth is supported on 500mm × 500mm columns. If the total uniformly distributed load on the beam is 10MN/m. The design shear force for the beam is
 A) 50.0 MN B) 47.5 MN C) 37.5 MN D) 43.0 MN
24. What is the anchorage value of a standard hook of a reinforcement bar of diameter D?
 A) 4D B) 8D C) 12D D) 16D
25. If A be the area of cross-section of a bar, the gauge length for the measurement of ductility will be
 A) $5.65 \times A^{1/2}$ B) $5.65 \times A$ C) $6.56 \times A^{1/2}$ D) $6.56 \times A$
26. The failure surface of a standard cast iron torsion specimen, subjected to a torque is along
 A) The surface helicoidal at 45° to the axis of the specimen
 B) The curved surface at the grips
 C) The plane surface perpendicular to the axis of the specimen
 D) The curved surface perpendicular to the axis of the specimen
27. For a solid circular section of diameter 'd' the stress in a column will be compressive only if the eccentricity of the line of action of the compressive force is within
 A) d/4 B) d/8 C) d/6 D) d/16
28. The number of unknowns to be determined in the stiffness method is equal to
 A) The static indeterminacy
 B) The kinematic indeterminacy
 C) The sum of kinematic and static indeterminacy
 D) Two times the number of supports
29. A concentrated load W moves on the span of a three-hinged arch. The horizontal thrust at the supports is maximum when the load is at which one of the following
 A) The springing B) One-sixth of the span from one end
 C) Quarter span D) The crown
30. A fixed beam of uniform section is carrying a point load at its midspan. If the moment of inertia of the middle half length is now reduced to half its previous value, then the fixed end moments will
 A) Change their directions B) Decrease
 C) Remain constant D) Increase
31. A beam carries a uniformly distributed load throughout its length. In which of the following configuration will the strain energy be maximum?
 A) Cantilever B) Simply supported beam
 C) Propped cantilever D) Fixed

32. A plate used for connecting two or more structural members intersecting each other is termed as
 A) Template B) Base plate C) Shoe plate D) Gusset plate
33. What is the allowable direct tensile stress in structural steel (approximately)
 A) $0.45f_y$ B) $0.75f_y$ C) $0.66f_y$ D) $0.60f_y$
34. M60 structural steel tube has a radius of gyration 20mm. The un-braced length upto which the tube can be used as a compression member, is
 A) 3.6 m B) 4.0 m C) 5.0 m D) 7.2 m
35. For a compression member having the same effective length about any cross-sectional axis, the most preferred section from the point of view of strength is
 A) A box B) An I-section C) A circular tube D) A single angle
36. For a steel built-up column subjected to an axial force of 1200 kN, the lacing system is to be designed for resisting transverse shear of
 A) 15 kN B) 20 kN C) 25 kN D) 30 kN
37. The allowable shear stress in the web of mild steel beams decreases with
 A) Decrease in h/t ratio B) Increase in h/t ratio
 C) Increase in thickness D) Decrease in height
38. A simply supported beam of uniform cross-section has span L and is loaded by a point load P at its mid-span. The length of elastoplastic zone of the plastic hinge will be
 A) $\frac{L}{3}$ B) $\frac{2L}{3}$ C) $\frac{2L}{5}$ D) $\frac{3L}{4}$
39. Surface tension of water
 A) First increases and then decreases with decrease in temperature
 B) Decrease with decrease in temperature
 C) Is independent of temperature
 D) Increase with decrease in temperature
40. Size of a venturimeter is specified by
 A) Pipe diameter
 B) Throat diameter
 C) Angle of diverging section
 D) Both pipe diameter as well as throat diameter
41. A building is an obstacle to
 A) Chaining but not ranging B) Ranging but not chaining
 C) Both chaining and ranging D) Neither chaining and ranging
42. A level line is a
 A) Horizontal line
 B) Line parallel to the mean spheroidal surface of earth
 C) Line passing through the centre of cross hairs and the centre of eye piece
 D) Line passing through the objective lens and the eye –piece of a dumpy or tilting level

43. Infiltration rate is always
A) More than the infiltration capacity
B) Less than the infiltration capacity
C) Equal to or less than the infiltration capacity
D) Equal to or more than the infiltration capacity
44. The meander pattern of a river is developed by
A) Average discharge
B) Dominant discharge
C) Maximum discharge
D) Critical discharge
45. A shallow foundation is defined as a foundation which
A) Has low bearing capacity
B) Is resting on the ground surface
C) Has a depth of embedment less than its width
D) Causes less settlement
46. The soils most susceptible to liquefaction are
A) Saturated dense sands
B) Saturated clays of uniform size
C) Saturated fine and medium sands of uniform particle size
D) Saturated gravels and cobbles
47. Soil pressure distribution below a rigid footing on the surface of a cohesive soil is
A) Maximum at the centre and minimum at edges
B) Uniform throughout
C) Minimum at the centre and maximum at edges
D) Maximum at one end minimum at the other end
48. A cantilever sheet pile derives its stability from
A) Lateral resistance of soil
B) Self weight
C) The deadman
D) The anchor rod
49. The mode of failure of a very short masonry member having h/t ratio of less than 4 is by
A) Shear
B) Vertical tensile splitting
C) Buckling
D) Crippling
50. For earthquake resistant masonry building, the vertical distance between opening one above the other in a load bearing wall shall not be less than
A) 50cm
B) 60cm
C) 75cm
D) 100cm

x-x-x

Community Development & Education(Ph.D.) (1077)

1. Socialism as a constitutional value implies education for
 - A) Social equity
 - B) Social equality
 - C) Social reconstruction
 - D) Social mobility

2. Internal criticism of historical data refers to
 - A) Establish authenticity of data source
 - B) Establish validity of the contents of data
 - C) Both (A) and (B)
 - D) None of these

3. Rearrange in proper order, the following activities related to test standardization
 - a) Preparation of test items
 - b) Planning the test
 - c) Assessment of reliability and validity
 - d) Tryout of the test
 - A) (b), (a), (d), (c)
 - B) (c), (d), (a), (b)
 - C) (d), (a), (b), (c)
 - D) (a), (d), (c), (b)

4. Which of the following correct order comes under Maslow's hierarchy of needs?
 - A) Self actualization, safety, love, esteem
 - B) Physiological need, self-actualization, esteem, safety
 - C) Physiological needs, safety, love, esteem, self actualization
 - D) Physiological need, esteem, self actualization, love

5. Phenomenology is a method basically used in
 - A) Educational research
 - B) Philosophical research
 - C) Historical research
 - D) Experimental research

6. Chi-square test is an example of
 - A) Parametric test
 - B) Non-Parametric test
 - C) Descriptive test
 - D) Survey test

7. Learning at one's own pace' is a special feature of
 - A) Teacher-centered method
 - B) Programmed instruction method
 - C) Learner-centered method
 - D) Activity-centered method

8. The National Policy on Education 1986 envisages Education as
 - A) Investment
 - B) Return
 - C) National Programme
 - D) Social Programme

9. Education falls under the
 - A) Concurrent List
 - B) Fundamental Rights
 - C) Constitution of India
 - D) State List

- 10.** Life skill education is needed
A) To adopt to one's own culture
B) To enhance vocational efficiency
C) To promote cultural integration
D) To face the challenges in life effectively
- 11.** Ivan Illich is renowned for
A) Life Long Learning
B) Life Skill Education
C) De Schooling Society
D) Open education
- 12.** If in a situation every individual has an equal chance of being selected, there it is a case of
A) Quota sampling
B) Non-probability sampling
C) Purposive sampling
D) Probability sampling
- 13.** Sociology of Education is
A) A branch of Anthropology
B) A study of the Society
C) An analysis of Sociological processes involved in the institutions of Education.
D) A science, which studies primitive societies
- 14.** Research ethics do NOT include
A) Objectivity
B) Honesty
C) Subjectivity
D) Integrity
- 15.** Amongst the following Indian States which one has the minimum total forest cover?
A) Sikkim
B) Goa
C) Haryana
D) Kerala
- 16.** If waste materials contaminate the source of drinking water which of the following diseases will spread?
A) Hemophilia
B) Typhoid
C) Malaria
D) Anemia
- 17.** Reservation of seats for women in Panchayati Raj bodies seeks to ensure
A) Economic welfare of women and children
B) Gender parity in rural society
C) Participation of women in public life
D) Empowerment of women as an individual
- 18.** Which of the following states does not have Panchayati Raj Institution at all?
A) Assam
B) Tripura
C) Kerala
D) Nagaland
- 19.** Universal Declaration of Human Rights contains
A) 20 Articles
B) 22 Articles
C) 30 Articles
D) 36 Articles
- 20.** Cultural and educational rights do not includes the provisions
A) Minorities have a right to protection.
B) Minorities can preserve their language script, law and culture.
C) Minorities cannot set up educational institutions.

D) Governments will not discriminate while giving grants to minority institutions

21. Right to Information Act 2005 was the culmination of the sustained efforts of

A) Baba Amte B) Savita Sinha C) Aruna Roy D) Anna Hazare

22. In Community Development, the word 'jack-of-all-trades and master of none' the title is given to

A) Village-level Workers B) Supervisors

C) Officers D) Politicians

23. Society is the total social heritage of folkways, mores and Institutions, of habits, sentiments and ideals. This is a ——— view of society.

A) Structural B) Cultural

C) Functional D) None of the above

24. Identify the forms of marriage widely prevalent in Tribal society

A) Service marriage B) Gandharva marriage

C) Asura marriage D) Probationary marriage

25. Some of the modern changes, which have taken place in the Hindu Marriage, are

A) Marriage is held as compulsory

B) No provision for divorce

C) Widow Remarriage permitted

D) Two living wives permissible to a husband

26. The Special Marriage Act was passed in the year

A) 1872 B) 1912 C) 1940 D) 1953

27. Which is the most important factor, which seems to be acting to reduce class differences in India?

A) Missionaries of social workers

B) Spread of information through mass- media such as the T.V

C) Rise in standard of living of the working class

D) Government's legal and social welfare efforts on improving the lot of the weaker sections of the society

28. A two-way systematic conversation between an investigator and respondent is called

A) Observation B) Schedule C) Interview D) Simulation

29. Failure to acknowledge the borrowed material is called (Take and use of others as one's own)

- B) The findings of previous research
C) Experience of the researcher
D) The results of the same study
- 39.** When was the Universal Declarations of Human Rights adopted?
A) 10th Dec 1948
B) 10th Dec 1949
C) 10th Dec 1950
D) 10th Dec 1947
- 40.** Lok Sabha passed-The rights of Person with Disabilities Bill-2016 on
A) 26/12/2016
B) 16/12/2016
C) 24/12/2016
D) 22/12/2016
- 41.** Which of the following organizations looks after the credit needs of agriculture and rural development in India?
A) FCI
B) IDBI
C) NABARD
D) ICAR
- 42.** Which one of the following was launched with the objective of helping the poor in rural areas to become self-employed?
A) DPAP
B) IRDP
C) TRYSEM
D) DDP
- 43.** Saakshar Bharat Awards are given for outstanding contribution in which field
A) Literature
B) Literacy Programs
C) Sports
D) Research
- 44.** NMEICT stands for
A) National Mission on Education through ICT
B) National Mission on E-governance through ICT
C) National Mission on E-commerce through ICT
D) National Mission on E-learning through ICT
- 45.** The technique of measurement of the patterns of social behaviour in a group is known as
A) Sociometry
B) Interaction analysis
C) Social distance scale
D) Sociogram
- 46.** The type of education imparted by family to the child is
A) Deliberate
B) Regular
C) Formal
D) Informal
- 47.** When the questions are presented to the respondents in a face-to-face situation, and the interviewer rather than the subjects, fills out the query, it is called
A) A schedule
B) A test
C) An inventory
D) A questionnaire

48. HRD process variable include

- A) Role clarity
- B) Work planning
- C) Better communication
- D) All of the above

49. promotes creation of national committees and societies for health education

- A) International Labour Organization
- B) Red Cross
- C) Health Promotion Council
- D) International Union for Health Education

50. A teacher finds out, by Sociometry, that her class comprises cliques, groups, stars, mutual and isolates. Who is an isolate?

- A) One who is liked by most classmates?
- B) One who is not at liked by any classmate?
- C) One who is not liked by anybody and who does not like anybody?
- D) One who likes a person and the second one like him?

x-x-x

Computer Science & Engineering(Ph.D.) (1077)

1. A binary search tree with height h as the number of edges in the longest path from the root to the leaf. The maximum number of nodes possible in the tree is
 - A) $2^{h-1} - 1$
 - B) $2^{h+1} - 1$
 - C) $2^h + 1$
 - D) $2^{h-1} + 1$

2. A circular queue is implemented using an array of size 12. The array index starts with 0, front is 8 and rear is 11. The insertion of next element takes place at the array index
 - A) 0
 - B) 1
 - C) 9
 - D) 12

3. If size of physical address and logical address is same then
 - A) Memory can be efficiently allocated.
 - B) Memory organization can be made efficient.
 - C) MMU is not required
 - D) CPU scheduling can be made efficient.

4. Which of the following regular expression is equivalent to the regular expression $(00 + 0 + 1)^*$
 - A) $(00 + 1)^*$
 - B) $(0 + 1)^*$
 - C) $(00 + 0 + 1)$
 - D) $(00 + 1)$

5. The time complexity of a Turing machine to recognize L over $\{0,1\}$ such that $L = \{w|w \text{ is of even length}\}$ is of order
 - A) n
 - B) n^2
 - C) n^3
 - D) $N \log n$

6. A CPU generates 30-bit virtual addresses. The page size is 2 KB. The processor has a translation look-aside buffer (TLB) which can hold a total of 64 page table entries and is 4-way set associative. The minimum size of the TLB tag is
 - A) 9 bits
 - B) 10 bits
 - C) 11 bits
 - D) 12 bits

7. Which of the following is in Greibach normal form?
 - A) $X \rightarrow YZ$
 - B) $X \rightarrow x$
 - C) $X \rightarrow Yx$
 - D) $X \rightarrow xY$

8. Fetching more number of pages rather than a single page during each page fault is called
 - A) Pre paging
 - B) Post paging
 - C) Pseudo paging
 - D) False paging

9. In which of the following sorting algorithm, the number of comparisons needed is the minimum if the items are initially in reverse order and is the maximum if the items are in order
- A) Straight insertion sort
 - B) Binary insertion sort
 - C) Heap sort
 - D) Bubble sort
10. The stack of LL parser holds
- A) Only terminals
 - B) Only non-terminals
 - C) Grammar symbols
 - D) Grammar symbols as well as states
11. The size of message digest generated by secure hash algorithm-1 for 512 bit message is
- A) 80 bits
 - B) 160 bits
 - C) 256 bits
 - D) 512 bits
12. In a 5-stage pipeline, the pipeline stages take 1, 2, 3, 2, 1 units of time. The throughput of the pipeline is
- A) 9
 - B) $\frac{1}{9}$
 - C) $\frac{1}{3}$
 - D) 2
13. The number of times “Hello World” is printed by the following C program is
- ```
main()
{
printf(“Hello World\n”);
main();
}
```
- A) Infinite number of times
  - B) 32767 times
  - C) Till the run-time stack does not overflow
  - D) 65535 times
14. In C programming language, which of the following statements can be used to terminate the current iteration of a loop?
- A) Break statement
  - B) Continue statement
  - C) Return statement
  - D) None of these
15. Consider the following fragment of C code. How many times will the following loop be executed?
- ```
x=100;
while(x<=100)
{
x=x-120;
if(x<0) break;
}
```

- A) 0
B) 20
C) 100
D) 1
16. What can be the minimum and maximum number of elements in a heap of height 4
A) 0,16
B) 16,31
C) 16,32
D) 8,16
17. The solution of the recurrence relation $T(n) = 8T\left(\frac{n}{2}\right) + n \log n$ is
A) $\Theta(n \log n)$
B) $\Theta(n^2 \log n)$
C) $\Theta(n^3)$
D) $\Theta(n^2)$
18. Which of the following statements are true
I. For undirected Hamiltonian Cycle Problem, a solution in polynomial time can be generated to find all Hamiltonian paths.
II. Directed Hamiltonian Cycle Problem is a NP hard problem
III. Solution to Hamiltonian Cycle Problem can be generated using Backtracking approach
A) All are true
B) Only I is true
C) All are false
D) II and III are true
19. For merging two sorted lists of sizes m and n into a sorted list of size m+n, we require comparisons of
A) $O(m)$
B) $O(n)$
C) $O(m+n)$
D) $O(\log(mn))$
20. Which of the following function has lowest asymptotic order of growth
A) $\log n$
B) $\log(\log n)$
C) $n^{\log(n)}$
D) n^n
21. Given three problems P_1 , P_2 and P_3 . The problem P_1 has polynomial time solution, P_2 is NP-complete and P_3 is in NP. Which of the following is TRUE?
A) P_3 has polynomial time solution if P_1 is polynomial time reducible to P_3 .
B) P_3 is NP-complete, if P_3 is polynomial time reducible to P_2 .
C) P_3 is NP-complete if P_2 is reducible to P_3 .
D) P_3 has polynomial time complexity if P_3 is reducible to P_2 .
22. In CRC, if the size of divisor is 10 bits then what is the degree of generator polynomial?
A) 9
B) 10
C) 11
D) 12

23. Given a memory system in which the cache memory access time is 10ns and main memory access time is 100ns. If the cache memory has hit ratio of 90%, then the average access time of the memory is
- A) 20ns
 - B) 45ns
 - C) 55ns
 - D) 90ns
24. Which of the following protocol is used to provide the error and flow control mechanism?
- A) IGMP
 - B) ICMP
 - C) ARP
 - D) DHCP
25. Consider a system with demand paging, it takes 100 ns to serve request if page is in memory and it takes 4 ms if it not in memory. What should be page fault rate, if we want to achieve effective access time of $2\mu\text{s}$.
- A) 29.98%
 - B) 49.98%
 - C) 4.998%
 - D) 19.99%
26. The symbol table implementation which is based on the property of locality of reference is
- A) Linear list
 - B) Self-organizing list
 - C) Search tree
 - D) Hash table
27. While generating intermediate code, CALL statement is implemented using
- A) MOV
 - B) GOTO
 - C) MOV and GOTO
 - D) HALT
28. Which of the following is used to determine which name is present in which register
- A) Symbol table
 - B) Hash table
 - C) Register descriptor
 - D) Address descriptor
29. The number of 128×8 RAM chips required to form a memory capacity of 2048 bytes is
- A) 8
 - B) 16
 - C) 24
 - D) 32
30. The simplified form of the Boolean expression $(A + B + AB)(A + C)$ is
- A) $A + B + C$
 - B) $AB + BC$
 - C) $A + BC$
 - D) $AC + B$

31. Binary modulo- n counter can be constructed using at least
- A) n flip-flops
 - B) 2^n flip-flops
 - C) n^2 flip-flops
 - D) $\log_2 n$ flip-flops
32. The number of clock pulses required to shift a byte of data into and out of a 8-stage parallel-in, parallel-out shift register is
- A) 1
 - B) 4
 - C) 8
 - D) 12
33. Which of the following is not a valid HTTP method?
- A) GET
 - B) POST
 - C) PATCH
 - D) SUBMIT
34. Which of the following methods is used to submit data in a transparent TCP/IP tunnel.
- A) GET
 - B) POST
 - C) PUT
 - D) CONNECT
35. Which of the following routing algorithms always ensures the shortest path even though routers crash during the course of routing?
- A) Flooding
 - B) Distance vector
 - C) Link state routing
 - D) Path vector routing
36. To provide more subnets, a class B address is assigned the subnet mask of 255.255.248.0. How many hosts are possible per subnet?
- A) 2048
 - B) 2046
 - C) 2044
 - D) 4096
37. What is the transmission time for a 5 M byte message if the bandwidth of a network is 1 Mbps
- A) 40 s
 - B) 5 s
 - C) 50 s
 - D) 0.2 s
38. If the size of a Hamming code is 11, then how many parity bits are required
- A) 1
 - B) 2
 - C) 3
 - D) 4

39. How many characters (5 data bits and 3 parity bits) per second can be transmitted (1 start and 1 stop bit) over a channel of 3000 bps, if the transfer is asynchronous..
- A) 320
 - B) 400
 - C) 100
 - D) 160
40. The rule “DBMS should not allow any low level language to bypass the integrity rules and constraints defined” is called
- A) Data sublanguage rule
 - B) Information rule
 - C) Non-subversion language rule
 - D) View updating rule
41. Which of the following function do not ignore NULL values
- A) MAX
 - B) COUNT
 - C) SUM
 - D) COUNT(*)
42. Functional Dependency where R.H.S is functionally determined by L.H.S but not by any subset of L.H.S, is called
- A) Non Functional Dependency
 - B) Fully Functional Dependency
 - C) Time Dependent FD
 - D) Transitive Dependency
43. In a clustered index, if position of key is 20th and record size is 40 bytes, then the desired record is after
- A) 800 bytes
 - B) 840 bytes
 - C) 760 bytes
 - D) 720 bytes
44. If one transaction has 4 instructions and another has 3 instructions, then number of non serial transactions can be generated are
- A) 7
 - B) 12
 - C) 49
 - D) 35
45. If the main memory is of 8Kbytes and the cache memory have 2K words. If cache memory use associative mapping scheme, then each word in the cache memory is of
- A) 11 bits
 - B) 21 bits
 - C) 16 bits
 - D) 20 bits
46. Which of the following arithmetic operations is generally not included as a micro-operation:
- A) Addition
 - B) Subtraction
 - C) Multiplication
 - D) Increment

47. Consider a demand paged memory system with memory access time of 125 microseconds. The page fault service time is 400 milliseconds. If page fault rate is 0.1% then what is the effective access time?
- A) 525 microseconds
 - B) 500 microseconds
 - C) 480 microseconds
 - D) 525 milliseconds
48. If we have 5 bubbles in level 1 DFD and each bubble is decomposed into 4 bubbles in level 2 DFDs. Then at most how many level 3 DFD can we have
- A) 5
 - B) 4
 - C) 20
 - D) Any value depends upon problem
49. The reliability of a program is 70% and its equivalent version has 80%. What are the chances of both of these to give wrong result to same input.
- A) 80%
 - B) 70%
 - C) 56%
 - D) 6%
50. If a particular website has to be used by million users to download contents, then which of the following testing ensure the proper working of website.
- A) Stress testing
 - B) Regression testing
 - C) Security testing
 - D) Recovery testing

Dance (1077)

1. Pick the odd one out
A) Teen Taal
B) Dhamar
C) Tilwara Taal
D) Pancham Sawari
2. The hand gestures are known as
A) Anga
B) Mudaras
C) Karnas
D) Mandal
3. In Bharatnatyam Padam means
A) Mystic Eroticism
B) Poetic Dance
C) A love lyric
D) Revelation of dance poses
4. Kumin dress is related to which form of classical dance
A) Kathak
B) Kathakali
C) Bharatnatyam
D) Manipuri
5. Jatisawaram is an item from thr repertoire of:
A) Bharatnatyam
B) Odissi
C) Kuchipudi
D) Khatakali
6. Pandit Sundar Prasad belonged to which Gharana
A) Luckhnow
B) Benaras
C) Jaipur
D) Delhi
7. Bihu dance is of which state
A) Tamil Nadu
B) Bengal
C) Assam
D) Haryana
8. Hallu Galuu is a popular folk dance of
A) Andhra Pradesh
B) Tamil Nandu
C) Telangana
D) Karnataka
9. Bon Odori dance belongs to
A) Japan
B) Thailand
C) China
D) Burma
10. How many types of classical dances persist in India
A) 6
B) 4
C) 10
D) 8
11. Khamba in Manipuri dance belonged to which clan
A) Kushumal
B) Tampak
C) Moirang
D) Imphal
12. According to Abhinaya Darpan how many Asanyukt mudras are used in dance

- A) 30
- B) 24

- C) 12
- D) 14

13. Who made the Lingaraj temple in Bhuwaneshwar

- A) King Jayati Kesari
- B) King Rama

- C) King Ashoka
- D) Queen Kalavati

14. Maharis are

- A) Temple dancing girls
- B) Street dancers

- C) Temple dancing boys
- D) Classical dancers

15. Batu Nritya portrays the worship of which god

- A) Lord Ganesha
- B) Lord Vishnu

- C) Lord Shiva
- D) Lord Rama

16. Lord Shiva's dance form is

- A) Bharatnatyam
- B) Tandav

- C) Lasaya
- D) Kathak

17. Gutipuas are related to which form of dance

- A) Odissi
- B) Kuchipudi

- C) Bhangara
- D) Lion dancing

18. The festive lantern dance belongs to which country

- A) Nepal
- B) China

- C) Sri Lanka
- D) Vietnam

19. Dandaas is the dance form of which state

- A) Punjab
- B) Uttar Pradesh

- C) Haryana
- D) Bihar

20. Himachal is famous for

- A) Bhangra
- B) Nati

- C) Karthi
- D) Garba

21. Seraikella Chhau is done in which state

- A) West Bengal
- B) Assam

- C) Bihar
- D) Andhra Pradesh

22. Yakshagana plays are written in which language

- A) Telugu
- B) Tamil

- C) Kannada
- D) Tullu

23. Satriya dance form originated in which state

- A) Assam
- B) Gujarat

- C) Karnataka
- D) Andhra Pradesh

- 24.** Which dance form of Assam is similar to Nati
 A) Khol
 B) Vyahar
 C) Ojapali
 D) Sword dance
- 25.** How many Rasa are there in Natya Shastra
 A) 9
 B) 10
 C) 8
 D) 14
- 26.** Nepathaya Viddhan is
 A) Sattvika Abhinaya
 B) Vachika Abhinaya
 C) Angik Abhinaya
 D) Aharya Abhinaya
- 27.** Burma is famous for
 A) Dragon dance
 B) Lion dance
 C) Kandhaya dance
 D) Puppet dance
- 28.** Dance theatre of China
 A) Peking Opera
 B) Bunrcku
 C) Noh
 D) Sarugaku
- 29.** Select the correct sequence
 A) Kurma, Narsimha, Matsya, Baman
 B) Matsya, Kurma, Varaha, Narsimha
 C) Kurma, Kalki, Matsya, Kurma
 D) Matsya, Krishna, Narsimha, Kalki
- 30.** How many neck movements are used in dance
 A) 6
 B) 5
 C) 4
 D) 10
- 31.** Who is the writer of Geet Gobind
 A) Pandit Jasraj
 B) Bhagat Singh
 C) Jaidev
 D) Tagore
- 32.** What is Mekhla
 A) Neck piece
 B) Dress
 C) Earing
 D) Anklet
- 33.** The sign of Anudruth is
 A) U (half moon)
 B) 1
 C) 0
 D) S
- 34.** How many Jaatis are there
 A) 5
 B) 6
 C) 4
 D) 3

35. According to Jaati whose matra is changed when new taals are formed

- A) Anudruth
- B) Laghu
- C) Druth
- D) Guru

36. What is Gopuchha

- A) Jaati
- B) Laya
- C) Yati
- D) Kala

37. How many taal Padhatis are there in India

- A) 2
- B) 3
- C) 6
- D) 5

38. How many basic taals are there in Dakshini taal Padhati

- A) 7
- B) 108
- C) 35
- D) 40

39. Who was Birju Maharaj's father

- A) Shambhu Maharaj
- B) Acchan Maharaj
- C) Lachhu Maharaj
- D) Bindadeen Maharaj

40. Guru Rajendra Gangani belongs to which Gharana

- A) Benaras
- B) Jaipur
- C) Lucknow
- D) Delhi

41. Shobhna Narayana is associated with which form of dance

- A) Bharatnatyam
- B) Kathak
- C) Kuchipudi
- D) Mohiniattam

42. The twins Shilpakarma and Manikarma dealt with

- A) Sitar players
- B) Dancers
- C) Tabala players
- D) Singers

43. The koothu dance belongs to

- A) Tamil
- B) Telugu
- C) Sanskrit
- D) Kannada

44. Kuravanji plays are related to

- A) Temples
- B) Homes
- C) Courts
- D) Streets

45. Name the mudra in which the ring finger is bent

- A) Pataka mudra
- B) Ardhchandra mudra
- C) Tripataka mudra
- D) Kapoth mudra

46. When the tips of all the five fingers meet it is known as

- A) Sandash
- C) Sarapseeesh

B) Mukul

D) Trishul

47. How many matras Rupak taal has

A) 8

C) 15

B) 7

D) 6

48. The instrument used in kathakali dance is

A) Chenda

C) Cymbal

B) Pakhawaj

D) Sarangi

49. Who wrote the maximum number of Thumris in kathak dance

A) Narayan Prasad

C) Bindadeen

B) Thakur Prasad

D) Kalika Prasad

50. Match the following

List I

a. Punjab

List II

1. Tera Talli

b. Rajasthan

2. Dandiya

c. Maharashtra

3. Sammi

d. Gujarat

4. Lavani

a. b. c. d.

A) 1. 2. 3. 4.

B) 3. 1. 4. 2.

C) 2. 4. 1. 3.

D) 4. 3. 2. 1.

x-x-x

Defence Studies(Ph.D. & M.Phil.) (1077)

1. Who stated that, “The art of war is certainly the noblest of all arts, so in the progress of improvement it necessarily becomes one of the most complicated among them?”
A) Sun tzu B) Adam Smith C) Karl Marx D) Mao-Tse-Tung

2. Which of the following concepts are not associated with Mackinder’s theory?
i) Pivot Area ii) Heartland iii) Midland Basin iv) Rimland
Select the correct answer using the codes given below.
A) i) and iii) B) iii) only C) iv) only D) iii) and iv)

3. Who defined, “ Tactics is the theory of the use of military forces in combat,” while “Strategy is the theory of the use of combats for the object of the war?”
A) Jomini B) Napoleon C) Liddle Hart D) None of them

4. Who wrote, “Report on Manufactures?”
A) Friedrich List B) Alexander Hamilton
C) Adam Smith D) Friedrich Engels

5. Frederick the Great invaded ‘Silesia’ for the first time in_____.
A) November 1740 B) December 1740
C) November 1741 D) December 1741

6. Which of the following were the fundamental factors that affect the development of Sea Power, according to Mahan?
i) Physical Configuration ii) Geographical Position
iii) Industrial Development iv) National Character
Select the correct answer using the codes given below
A) i) and iii) B) i), ii) and iii) C) i), ii) and iv) D) All of them

7. Who coined the term ‘Geopolitics’?
A) Karl Ritter B) Friedrich Ratzel C) Mackinder D) Rudolf Kjellén

8. Chinese Admiral ‘Zheng He’ led the long voyages to far off shores under which of the following dynasties?
A) Ming B) Qing C) Han D) Sui

9. ‘Oisivetes’ are related to which of the following thinkers?
A) Jomini B) Jean Errard C) Count de Pagan D) None of them

10. Which of the following are the Pushtun tribes?
i) Durrani ii) Ghilzai iii) Karlanri iv) Sarbani
Select the correct answer using the codes given below
A) i) and ii) B) i), ii) and iv) C) i) and iv) D) All of them

11. Who stated that, “The Christian, Jewish and Hindu civilizations have nuclear capability, along with Communist powers? Only the Islamic civilization was without it, but the situation was about to change. What difference does my life make now when I can imagine eighty million of my countrymen standing under the nuclear cloud of a defenseless sky?”

- A) Mahmoud Ahmedinejad B) Hassan Rouhani
C) Zulfikar Ali Bhutto D) Abdul Qadir Khan

12. Who authored the famous military work titled, “Principes Generaux de la Guerre?”

- A) Jomini B) Clausewitz C) Guibert D) Fredrick the Great

13. Which of the following islands are located in South China Sea?

- i) Pratas Islands
ii) Paracel Islands
iii) [Cát Bà Island](#)

Select the correct answer using the codes given below

- A) ii) B) i) and ii) C) ii) and iii) D) All of them

14. Nine Degree Channel separates _____.

- A) Car Nicobar and Great Nicobar B) Lakshdweep and Minicoy
C) Little Andaman and Car Nicobar D) North Andaman and South Andaman

15. Which of the following is not located in Indian Ocean Region?

- i) Bab-el-Mandeb Strait
ii) Strait of Tiran
iii) Cook Strait
iv) Zanzibar Channel

Select the correct answer using the codes given below

- A) iii) and iv) B) ii) and iii) C) iii) D) iv)

16. Emperor *Shǐ Huángdì* belonged to which dynasty of China?

- A) Qin B) Sui C) Han D) Ming

17. Asymmetrical globalization is:

- A) The way in which contemporary globalization is equally experienced across the world and amongst different social groups.
B) The way in which contemporary globalization is unequally experienced across the world and amongst different social groups.
C) The degree to which networks or patterns of social interaction are formally constituted as organizations with specific purposes.
D) A process in which the organization of social activities is increasingly less constrained by geographical proximity and national territorial boundaries.

18. What is the Realist image of the state?

- A) The state is the most important actor of international politics and sovereignty is its distinguishing trait
- B) The state will always seek to ensure its survival in a perilous international environment.
- C) The state behaves morally and in accordance to what its population's values are.
- D) The state is the most important actor of international politics, sovereignty is its distinguishing trait and the state will always seek to ensure its survival in a perilous international environment.

19. What is the “ethic of responsibility” and how does it relate to world politics?

- A) It marks the limits of ethics in international relations; this results in decision-makers weighing up consequences and sometimes expecting positive outcomes of amoral actions.
- B) It is a vow politicians take, which requires them to take responsibility for the ethics of their international actions.
- C) It is the responsibility realists have towards the world; this creates a more realistic scene in world politics
- D) None of the options given are correct

20. India has Kalapani and Susta territorial dispute with

- A) Bangladesh B) Bhutan C) Nepal D) Myanmar

21. Wassenaar arrangement seeks to bring transparency in the export of

- i) conventional arms
- ii) dual-use goods
- iii) small arms and light weapons
- iv) military aircraft

Select the correct answer using the codes given below.

- A) i) and ii) only B) i), iii) and iv) only
 C) ii), iii) and iv) only D) i), ii), iii) and iv)

22. The Kaladan transport project by India and Myanmar consists of which of the following modes of transport?

- i) roads
- ii) railways
- iii) shipping
- iv) inland water transport

Select the correct answer using the codes given below.

- A) i), ii) and iii) only B) i), iii) and iv) only
 C) ii), iii) and iv) only D) i) , ii), iii) and iv)

23. India has signed Comprehensive Economic Partnership Agreement (CEPA) with

- i) USA
- ii) Singapore
- iii) Japan

Select the correct answer using the codes given below.

- A) i) and ii) only B) iii) only C) ii) and iii) only D) i), ii) and iii)

24. Which of the following is the first step in starting the research process?

- A) Searching sources of information to locate problem
- B) Survey of related literature
- C) Identification of problem
- D) Searching for solutions to the problem

25. The essential qualities of a researcher are

- A) Spirit of free enquiry
- B) Reliance on observation and evidence
- C) Systematization or theorizing of knowledge
- D) All of the above

26. Inductive logic proceeds from :

- A) General to General B) Particular to General
- C) General to Particular D) Particular to Particular

27. What is a research design?

- A) A way of conducting research that is not grounded in theory
- B) The choice between using qualitative or quantitative methods
- C) The style in which you present your research findings, e.g. a graph
- D) A framework for every stage of the collection and analysis of data

28. Hypothesis must have _____

- A) Applicability B) Durability C) Testability D) Measurement

29. Scientific method is committed to _____

- A) Objectivity B) Ethics C) Proposition D) Neutrality

30. Ethical Neutrality is a feature of _____

- A) Deduction B) Scientific method C) Observation D) Experience

31. Theory is “ a set of systematically related propositions specifying causal relationship among variables” is defined by

- A) Black James and Champion B) P.V. Young
- C) Emory D) Gibbes

32. The first step in formulating a problem is

- A) Statement of the problem B) Gathering of Data
- C) Measurement D) Survey

33. “Foundations of Behavioral Research” is written by

- A) P.V. Young B) [Fred Nichols](#) Kerlinger

C) Emory

D) Clover Verno

34. Constructivists argue that...

- A) Scientific enquiry can uncover absolute truths
- B) Material forces are much more important than ideas
- C) Individuals are powerless to shape the world as they find it
- D) The 'truth' is always socially constructed

35. Where are the headquarters of International Seabed Authority (ISA)?

- A) Berlin
- B) Paris
- C) New York
- D) Kingston

36. "Sahyog-Hyeobleod-2016" is the joint naval exercise between India and_____.

- A) Singapore
- B) South Korea
- C) Vietnam
- D) Malaysia

37. Who is the author of the book "The Other Side of Silence: Voices from the Partition of India"?

- A) Khushwant Singh
- B) Yasmin Khan
- C) Sathya Sothanai
- D) Urvashi Butalia

38. The 13th amendment has been a point of contention between India and Sri Lanka. The 13th amendment provided for

- i) Establishment of provincial councils.
- ii) Taking action against the human rights violators
- iii) Creation of a second chamber in central legislature.

Select the correct answer using the codes given below.

- A) i) only
- B) i) and ii) only
- C) ii) and iii) only
- D) i), ii) and iii)

39. Which of the following are the magazines published by ISIS

- i) Rumiya
- ii) Dabiq
- iii) Daesh

Select the correct answer using the codes given below

- A) i) only
- B) ii) only
- C) i) and ii) only
- D) ii) and iii) only

40. From which of the following countries has India purchased the Pilatus PC-7 trainer aircraft

- A) United States of America
- B) France
- C) Switzerland
- D) Germany

41. Who was the author of the book, "The Myth of the Independence"?

- A) Z. A. Bhutto
- B) M.A. Jinnah
- C) Sartaz Aziz
- D) Khan Abdul Ghaffar Khan

42. What was the name given to the operation conducted by National Security Guard in 2008 against terrorist attack in Taj hotel, Mumbai?

- A) Operation Black Tornado
- B) Operation Black Thunder
- C) Operation Safed Sagar
- D) Operation Vijay

43. Which river in Afghanistan joins the Indus in Pakistan?
A) Amu B) Hilmand C) Harirud D) Kabul
44. "Collective Security of Asia" concept was initiated by
A) L. Breznev B) J.L. Nehru
C) Abdul Jamal Nasser D) Nelson Mandela
45. Operation cactus relates to
A) IPKF assistance in Sri Lanka
B) NSG anti-terrorist operation in Punjab
C) Indian army's assistance to Maldives Government
D) American operation in Iran to relieve American hostages
46. The Sinatra doctrine:
A) Was a catchphrase for foreign policy under Gorbachev
B) Replaced the Khrushchev doctrine
C) Followed *glasnost* and *perestroika*
D) None of the above
47. Sendai Framework is related to
A) Water Security B) Climate Change
C) GWOT D) Disaster Risk Reduction
48. The first United Nations Framework Convention on Climate Change (UNFCCC) Conference took place in
- A) [Berlin, Germany](#) B) Geneva, Switzerland
C) Kyoto, Japan D) Buenos Aires, Argentina
49. The Second Artillery Corps of China has been renamed as
A) PLA Missile Force B) PLA Strategic Force
C) PLA Artillery Force D) PLA Rocket Force
50. Engineering Research Laboratories (ERL) in Pakistan were renamed as Khan Research Laboratory (KRL) by
A) Abdul Qadeer Khan B) Yahya Khan
C) Ayub Khan D) Zia-ul-Haq

x-x-x

Economics(1077)

- The curve which shows the number of hours that an individual offer to work at various wage rates is called
A) Trade off curve
B) Labour supply curve
C) Trade offer curve
D) Wage offer curve
- Those cash payments which firms make to outsiders for their services and goods are called
A) Real cost
B) Social costs
C) Explicit costs
D) Implicit costs
- Ridge lines can be defined as the
A) Loci of the maximum products
B) Loci of zero total products
C) Loci of zero marginal products
D) Loci of zero average products
- The elasticity is a measure of average elasticity.
A) Point
B) Price
C) Income
D) Arc
- Which of the theories given below have been propounded to explain the determination of interest rate?
A) Time preference theory
B) Loanable fund theory
C) Liquidity preference theory
D) All the above
- Which of the following is Not a subjective factor in the consumption function:
A) Social arrangements affecting the distribution of income
B) Social practice and institutions
C) Behaviour patterns of the government
D) Behaviour patterns of business concerns
- The formula for the equilibrium level of income for the four sector model would be:
A) $Y = 1 / 1 - b + m (a + \bar{I} + \bar{G} + \bar{X} - b \bar{T} - \bar{M})$
B) $Y = 1 / 1 - b - m (a + \bar{I} + \bar{G} + \bar{X} - b \bar{T} - \bar{M})$
C) $Y = 1 / 1 - m + b (a + \bar{I} + \bar{G} + \bar{X} - b \bar{T} - \bar{M})$
D) None of the above
- If the MPC value is 0.75, what will be the value of the tax multiplier?
A) 3
B) -3
C) -2.5
D) 2.5
- How does an expansionary monetary policy affect the rate of interest and level of income
A) Raises the rate of interest and lowers the level of income
B) Raises the level of income but lowers the rate of interest
C) Raises the rate of interest but lowers the level of income
D) Lowers both the rate of interest and level of income
- NNP at factor cost + Transfer payments+ interest on Public debt – social security – profits and surpluses of public undertakings is equal to
A) Personal income
B) Private income
C) Real income
D) Nominal income

11. Keynes deals with
 A) Full employment
 B) All levels of employment
 C) Surplus employment
 D) None of these
12. Change in investment outlays related to the changes in the rate of consumption expenditure via the acceleration coefficient measures the
 A) Leakage effect
 B) Leverage effect
 C) Linkage effect
 D) None of these
13. Non-legal tender money like cheques bank drafts, hundies, bills of exchange etc are called
 A) Optional money
 B) Near money
 C) Cheap money
 D) Liquid money
14. Excess of total expenditure over total receipts is known as
 A) Budgetary deficit
 B) Revenue deficit
 C) Fiscal deficit
 D) None of these
15. An economic integration in which member countries unify all their economic policies including monetary, fiscal and welfare policies as well as policies toward trade and factoral migration
 A) EU
 B) Common market
 C) Custom union
 D) Free trade agreement
16. The international monetary system that existed from 1947 to 1971 is generally known as the
 A) Par value system
 B) Pegged exchange rate system
 C) Both (A) and (B)
 D) Bretton woods system
17. The natural rate hypothesis of Friedman and Phelps
 A) Uses a rational expectations model
 B) Is based on forward looking expectation
 C) Assumes that economic agents use all available information in forming expectation
 D) Use an adaptive expectation model
18. The Laffer curve shows the relation between tax
 A) Revenue and tax
 B) Revenue and take home pay
 C) Revenue and govt. Spending
 D) Rates and take home pay
19. In the liquidity trap, Monetary policy
 A) Has a large impact on interest rate
 B) Has a small impact on interest rate
 C) Has no impact on interest rate
 D) Has a proportionate impact on interest rate
20. Under Cournot model of Duopoly, each duopolist will produce
 A) Half the output
 B) One fourth of the output
 C) One sixth of the output
 D) One third of the output
21. If MP_L / MP_k of capital does not change with any proportionate change in labour and capital, then the production function is
 A) Linear
 B) Non-linear
 C) Homogenous
 D) Homothetic

22. Inverted U shaped income distribution hypothesis is associated with
 A) JB Clark B) David Ricardo C) Simon Kuznets D) Adam Smith

23. Match the terms in the List-I with terms in List-II

List-I

- I) Structural view of underdevelopment
 II) Laissez Faire policy
 III) Departmental Scheme of Expanded reproduction
 IV) Golden age of accumulation

List-II

1. Classical Economists
 2. Hollis Chenery
 3. Steady state growth
 4. Karl Marx

Codes:

	I	II	III	IV
A)	2	1	4	3
B)	4	2	3	1
C)	1	3	2	3
D)	3	4	1	2

24. The exchange rate is kept the same in all parts of the market by
 A) Exchange arbitrage B) Interest arbitrage
 C) Hedging D) Speculation
25. Colin Clark has argued that for most causation of the world, the safe upper limit of taxation is
 A) 40% of national income B) 30% of national income
 C) 25% of national income D) 20% of national income
26. Random sampling implies that
 A) The observations are selected purposively
 B) The observations are selected in a systematic manner
 C) The observations are selected in an adhoc manner
 D) The observations are selected in clusters
27. X^2 (Chi Square) test is used to test
 A) Analysis off variance
 B) association between the qualitative variables
 C) difference between means of two distribution drawn from the same population
 D) difference between means of two distribution drawn from the different populations
28. In a binomial distribution, the sum of mean and variance is 15 and product of mean and variance is 54, then the number of observations (n) is equal to
 A) 27 B) 30 C) 24 D) 33
29. The total cost function and the market demand function of a competitive firm are $C=1/3x^3 - 10x^2 + 9x + 1000$ and $x=(12-p)/9$ respectively. The level of output at which profit will be maximised
 A) 1 B) 2 C) 3 D) 4
30. Let the two regression lines be given as $3x= 10+5y$ and $4y= 5+15x$. Then the correlation coefficient between x and y is
 A) -0.40 B) 0.40 C) 0.89 D) +1.05

31. The locus of Pareto Optimality in Production and Consumption is given by
 A) The social welfare function B) The utility possibility curve
 C) The transformation curve D) The grand utility possibility curve
32. The premise that benefit of economic growth will reach all sections of population is called
 A) Trickle up effect B) Trickle down effect
 C) Take off effect D) Backlash effect
33. According to Monetary approach, a revaluation of a nations currency
 A) Increases nations' demand for money B) Increases nations' supply of money
 C) Reduces the nations' demand for money D) Reduces the nations' supply of money
34. Which are the following is not an assumption of Linear Programming?
 A) Constant output prices B) Constant input prices
 C) Increasing returns to Scale D) Technologically fixed factor proportion
35. What is the main purpose of UNEP?
 A) Equal Development B) Economic Development
 C) Reduction in temperature D) Sustainable development
36. Grants from centre to states under the recommendations of Finance Commission are known as
 A) Plan grants B) Development Assistance
 C) Statutory grants D) Discretionary grants
37. In a multiple regression with three independent variables, the regression coefficients are to be tested. Which test would be used:
 A) Z test B) F test
 C) X^2 (Chi Square) test D) t-test
38. The practice of charging each consumer the reservation price is called
 A) Peak load pricing B) Inter-temporal price discrimination
 C) First degree price discrimination D) Third degree price discrimination
39. Frictional unemployment is also known as
 A) Disguised unemployment B) Turnover unemployment
 C) Cyclical unemployment D) Structural unemployment
40. Components of PQLI
 I) Morbidity
 II) Infant Mortality
 III) Life expectancy at age one
 IV) Basic literacy at age 15
Codes
 A) I, III and IV are correct B) III, II and IV are correct
 C) I, II, and III are correct D) IV, I and II are correct

41. An example of Euro Currency is
A) A dollar outside the U.S
B) A pound sterling deposit within U.S
C) A mark deposit with Germany
D) All of these
42. Public goods are characterised by
1) Collective Consumption
2) Divisibility
3) Non-exclusion
4) Rival consumption
Select the correct answer from the code given below
A) 1 and 2 are correct
B) 1 and 3 are correct
C) 1 and 4 are correct
D) 2 and 4 are correct
43. Who formulated the People's plan for India in 1947?
A) J L Nehru
B) M N Roy
C) Subhash Chandra Bose
D) Mahatma Ghandi
44. Who among following economists developed the concept of 'Barriers to Entry' of firms
A) J S Bain
B) W J Bamnol
C) Alfred Marshall
D) W S Jevons
45. Capital Adequacy Ratio of all commercial Banks in India is
A) Below the required rate of 9%
B) Equal to the required rate of 9%
C) Well above the required rate of 9%
D) Far below the required rate of 9%
46. Limit price refers to the:
A) Price which maximises the profits of the firm
B) Price which prevents entry of new firms
C) Price at which firm just starts earning surplus over cost
D) Maximum price which the firm is allowed to charge
47. How many countries are the members of EU
A) 25
B) 28
C) 26
D) 15
48. Among the following who are eligible to benefit from the 'Mahatma Gandhi National Rural Employment Guarantee act'
A) Adult members of only the Scheduled Caste and Scheduled tribes households
B) Adult members of Below Poverty Line (BPL) households
C) Adult members of households of all backward communities
D) Adult members of any household

49. A rapid increase in the rate of inflation is sometimes attributed to the 'base effect'. What is 'base effect'?
- A) It is the impact of drastic deficiency in supply due to failure of crops
 - B) It is the impact of the surge in demand due to rapid economic growth
 - C) It is the impact of the price levels of previous years on the calculation of inflation rate
 - D) None of the above
50. Both foreign direct investment (FDI) and foreign institutional investor (FII) are related to investment in a country. Which one of the following statements best represents an important difference between the two?
- A) FII helps bring better management skills and technology, while FDI only brings in capital
 - B) FII helps in increasing capital availability in general, while FDI only targets specific sectors
 - C) FDI flows only into the secondary market, while FII targets primary market
 - D) FII is considered to be more stable than FDI

x-x-x

Electronics & Communication Engineering(Ph.D.) (1077)

- The average power delivered to an impedance $(4-j3)\Omega$ by a current $5\cos(100\pi t + 100)$ A is
 A) 44.2 W B) 50 W C) 62.5 W D) 125 W
- In the following figure, C_1 and C_2 are ideal capacitors. C_1 has been charged to 12V before the ideal switch S is closed at $t = 0$. The current $i(t)$ for all t is

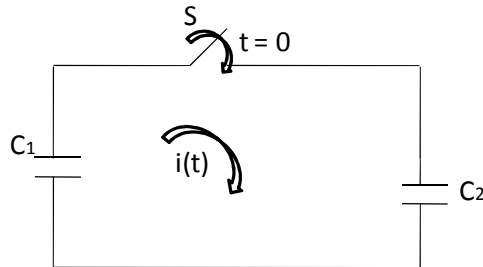

- A) Zero B) Step function
 C) An exponentially decaying function D) An impulse function
- For a parallel RLC circuit, which one of the following statements is not correct?
 A) The bandwidth of the circuit decreases if R is increased
 B) The bandwidth of the circuit remains the same if L is increased
 C) At resonance, input impedance is a real quantity
 D) At resonance, the magnitude of input impedance attains its minimum value.
 - In the circuit shown below, the value of R_L such that the power transferred to R_L is maximum is

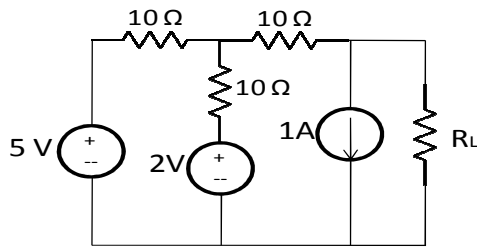

- A) 5Ω B) 10Ω C) 15Ω D) 20Ω
- Two 2-port networks are connected in parallel. The combination is to be represented as a single two-port network. The parameters of this network are obtained by addition of the individual
 A) Z-parameters B) H-parameters
 C) Y-parameters D) ABCD parameters
 - The first and last critical frequency of an RC-driving point impedance must respectively, be

- A) A zero and a pole
C) A pole and a pole
- B) A zero and a zero
D) A pole and a zero
7. A continuous-time function $x(t)$ is periodic with period T . The function is sampled uniformly with a sampling period T_s . In which one of the following cases is the sampled signal periodic?
A) $T = \sqrt{2}T_s$ B) $T = 1.2T_s$ C) Always D) Never
8. The impulse response of an LTI system can be obtained by
A) Differentiating the unit ramp response
B) Differentiating the unit step response
C) Integrating the unit ramp response
D) Integrating the unit step response
9. The Fourier transform of a conjugate symmetric function is always
A) Imaginary B) Conjugate antisymmetric
C) Real D) Conjugate symmetric
10. The first six points of the 8-point DFT of a real valued sequence are 5, $1-j3$, 0, $3-j4$, 0 and $3+j4$. The last two points of the DFT are respectively
A) 0, $1-j3$ B) 0, $1+j3$ C) $1+j3$, 5 D) $1-j3$, 5
11. If the Laplace transform of a signal $y(t)$ is $Y(s) = \frac{1}{s(s-1)}$, then its final value is
A) -1 B) 0 C) 1 D) Unbounded
12. Consider the sequence $x[n] = a^n u[n] + b^n u[n]$, where $u[n]$ denotes the unit-step sequence and $0 < |a| < |b| < 1$. The region of convergence (ROC) of the z-transform of $x[n]$ is
A) $|z| > |a|$ B) $|z| > |b|$ C) $|z| < |a|$ D) $|a| < |z| < |b|$
13. A thin P-type silicon sample is uniformly illuminated with light which generates excess carriers. The recombination rate is directly proportional to
A) The minority carrier mobility
B) The minority carrier recombination lifetime
C) The majority carrier concentration
D) The excess minority carrier concentration
14. n-type Silicon is obtained by doping Silicon with
A) Germanium B) Aluminium C) Boron D) Phosphorus
15. A region of negative differential resistance is observed in the current voltage characteristic of a silicon PN junction if
A) Both the P-region and the N-region are heavily doped
B) The N-region is heavily doped compared to the P-region
C) The P-region is heavily doped compared to the N-region
D) An intrinsic Silicon region is inserted between the P-region and the N-region.

16. A silicon PN junction is forward biased with a constant current at room temperature. When the temperature is increased by 10°C , the forward bias voltage across the PN junction

- A) Increases by 60mV
- B) Decreases by 60 mV
- C) Increases by 25 mV
- D) Decreases by 25 mV

17. The Ebers-Moll model of a BJT is valid

- A) Only in active mode
- B) Only in active and saturation modes
- C) Only in active and cut-off modes
- D) In active, saturation and cut-off modes

18. In IC technology, dry oxidation (using dry oxygen) as compared to wet oxidation(using steam or water vapour) produces

- A) Superior quality oxide with a higher growth rate
- B) Inferior quality oxide with a higher growth rate
- C) Inferior quality oxide with a lower growth rate
- D) Superior quality oxide with a lower growth rate

19. Under the DC conditions, the collector-to-emitter voltage drop is

- A) 4.8 Volts
- B) 5.3 Volts
- C) 6.0 Volts
- D) 6.6 Volts

20. Generally, the gain of a transistor amplifier falls at high frequencies due to the

- A) Internal capacitances of the device
- B) Coupling capacitor at the input
- C) Skin effect
- D) Coupling capacitor at the output

21. A Class A transformer coupled power amplifier is required to deliver a power output of 10 watts. The maximum power rating of the transistor should not be less than

- A) 5W
- B) 10W
- C) 20W
- D) 40W

22. The circuit below implements a filter between the input current i_1 and the output voltage v_o . Assume that the opamp is ideal. The filter implemented is a

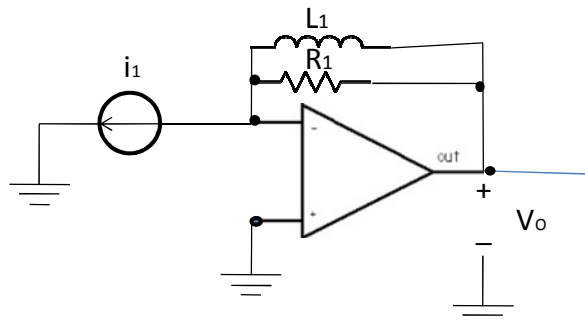

- A) Low pass filter
- B) Band pass filter
- C) Band stop filter
- D) High pass filter

23. The desirable characteristics of a transconductance amplifier are
- High input resistance and high output resistance
 - High input resistance and low output resistance
 - Low input resistance and high output resistance
 - low input resistance and low output resistance
24. For a given sample-and-hold circuit, if the value of the hold capacitor is increased, then
- Droop rate decreases and acquisition time decreases
 - Droop rate decreases and acquisition time increases
 - Droop rate increases and acquisition time decreases
 - Droop rate increases and acquisition time increases
25. The two numbers represented in signed 2's complement form are $P = 11101101$ and $Q = 11100110$. If Q is subtracted from P , the value obtained in signed 2's complement form is
- 100000111
 - 00000111
 - 11111001
 - 111111001
26. The minimum number of 2-input NAND gates required to implement a 2-input XOR gate is
- 4
 - 5
 - 6
 - 7
27. The output Y of a 2-bit comparator is logic 1 whenever the 2-bit input A is greater than the 2-bit input B . The number of combinations for which the output is logic 1 is
- 4
 - 6
 - 8
 - 10
28. The circuit shown in the figure is a

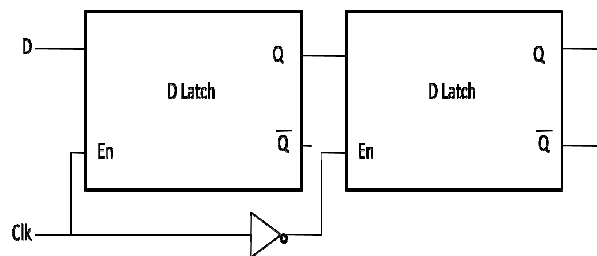

- Toggle flip flop
 - JK flip flop
 - SR flip flop
 - Master-Slave D flip flop
29. Among the digital IC-families-ECL, TTL and CMOS:
- ECL has the least propagation delay
 - TTL has the largest fan-out
 - CMOS has the biggest noise margin
 - TTL has the lowest power consumption

30. The minimum of comparators required to build an 8 bit flash ADC is
 A) 8 B) 63 C) 255 D) 256
31. An 8085 microprocessor based system uses a 4K X 8 bit RAM whose starting address is AA00H. The address of the last byte in this RAM is
 A) AFFFH B) 1000H C) B9FFH D) BA00H
32. In an 8085 microprocessor, the contents of the accumulator and the carry flag are A7(in hex) and 0, respectively. If the instruction RLC is executed, then the contents of the accumulator (in hex) and the carry flag, respectively, will be
 A) 4E and 0 B) 4E and 1 C) 4F and 0 D) 4F and 1
33. An 8085 microprocessor executes “STA 1234H”with starting address location 1FFEh. While the instruction is fetched and executed, the sequence of values written at the address pin $A_{15} - A_8$ is
 A) 1FH, 1FH, 20H, 12H B) 1FH, FEH, 1FH, FFH, 12H
 C) 1FH, 1FH, 12H, 12H D) 1FH, 1FH, 12H, 20H, 12H
34. In an 8085 microprocessor, the instruction CMP B has been executed while the content of the accumulator is less than that of register B. As a result
 A) Carry flag will be set but zero flag will be reset
 B) Carry flag will be reset but zero flag will be set
 C) Both Carry flag and zero flag will be reset
 D) Both Carry flag and zero flag will be set
35. The number of hardware interrupts present in an 8085 microprocessor are
 A) 1 B) 4 C) 5 D) 13
36. Consider the following block diagram in the figure. The transfer function $C(s)/R(s)$ is

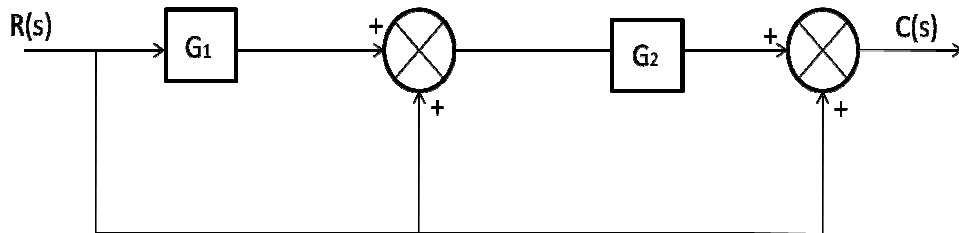

- A) $G_1G_2/(1 + G_1G_2)$ B) $G_1G_2 + G_1 + 1$
 C) $G_1G_2 + G_2 + 1$ D) $G_1/(1 + G_1G_2)$
37. If the characteristic equation of a closed-loop system is $s^2 + 2s + 2 = 0$, then the system is
 A) Overdamped B) Critically damped
 C) Underdamped D) Undamped

38. An amplifier with resistive negative feedback has two left half plane poles in its open-loop transfer function. The amplifier
- Will always be unstable at high frequencies
 - Will be stable for all frequencies
 - May be unstable, depending on the feedback factor
 - Will oscillate at low frequencies
39. If the open loop transfer function is a ratio of a numerator polynomial of degree 'm' and a denominator polynomial of degree 'n', then the integer (n-m) represents the number of
- Break away points
 - Unstable poles
 - Separate root loci
 - Asymptotes
40. The polar plot of the transfer function $G(s) = \frac{10(s+1)}{s+10}$ for $0 \leq \omega \leq \infty$ will be in the
- First quadrant
 - Second quadrant
 - Third quadrant
 - Fourth quadrant
41. If calls arrive at a telephone exchange such that the time of arrival of any call is independent of the time of arrival of earlier or future calls, the probability distribution function of the total number of calls in a fixed time interval will be
- Poisson
 - Gaussian
 - Exponential
 - Gamma
42. A message signal $m(t) = A_m \sin(2\pi f_m t)$ is used to modulate the phase of a carrier $A_c \cos(2\pi f_c t)$ to get the modulated signal $y(t) = A_c \cos(2\pi f_c t + m(t))$. The bandwidth of $y(t)$
- Depends on A_m but not on f_m
 - Depends on f_m but not on A_m
 - Depends on both A_m and f_m
 - Does not depend on A_m or f_m
43. The input to a coherent detector is DSB-SC signal plus noise. The noise at the detector output is
- The in-phase component
 - The quadrature component
 - Zero
 - The envelope
44. In a PCM system with uniform quantization, increasing the number of bits from 8 to 9 will reduce the quantization noise power by a factor of
- 9
 - 8
 - 4
 - 2
45. A source alphabet consists of N symbols with the probability of the first two symbols being the same. A source encoder increases the probability of the first symbol by a small amount ϵ and decreases that of the second by ϵ . After encoding, the entropy of the source
- Increases
 - Remains the same
 - Increases only if $N = 2$
 - Decreases

46. A metal sphere with 1m radius and surface charge density of 10 Coulombs/m^2 is enclosed in a cube of 10m side. The total outward electric displacement normal to the surface of the cube is
- A) 40π Coulombs B) 10π Coulombs
C) 5π Coulombs D) 15π Coulombs
47. For static electric and magnetic fields in a homogenous source-free medium, which of the following represents the correct form of two Maxwell's equations?
- A) $\nabla \cdot E = 0, \nabla \times B = 0$ B) $\nabla \cdot E = 0, \nabla \cdot B = 0$
C) $\nabla \times E = 0, \nabla \times B = 0$ D) $\nabla \times E = 0, \nabla \cdot B = 0$
48. A transmission line has a characteristic impedance of 50Ω and a resistance of $0.1 \Omega/\text{m}$. If the line is distortionless, the attenuation constant (in Np/m) is
- A) 500 B) 5 C) 0.014 D) 0.002
49. The phase velocity of waves propagating in a hollow metal waveguide is
- A) Greater than the velocity of light in free space
B) Less than the velocity of light in free space
C) Equal to the velocity of light in free space
D) Equal to the group velocity
50. The directivity of an antenna array can be increased by adding more antenna elements as a larger number of elements
- A) Improves the radiation efficiency
B) Increases the effective area of the antenna
C) Results in a better impedance matching
D) Allows more power to be transmitted by the antenna

x-x-x

Electrical Engineering(Instrumentation & Control)(Ph.D.) (1077)

1. The v-i characteristics of an element is shown in the Figure given below. The element is

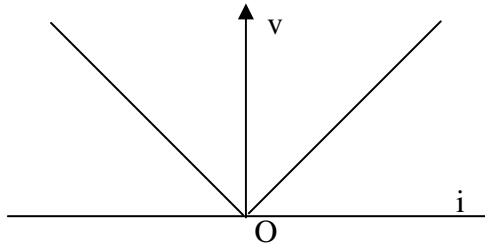

- A) non-linear, active, non-bilateral
 B) liner, active, non-bilateral
 C) non-linear, active, passive, non-bilateral
 D) non-linear, active, bilateral
2. A network function $Z(s) = \frac{V(s)}{I(s)}$ has a single pole at $s = -\frac{1}{\sqrt{3}}$ and a single zero $s = -\sqrt{3}$. If the excitation $V(t) = \sin t$, then what is the angle of lead or lag of the current ?
 A) Lead the voltage by 30°
 B) Lag the voltage by 30°
 C) Lead the voltage by 90°
 D) Lag the voltage by 90°
3. Given two coupled inductors L_1 and L_2 , then mutual inductance M satisfies
 A) $M = \sqrt{L_1^2 + L_2^2}$
 B) $M > \frac{L_1 + L_2}{2}$
 C) $M > \sqrt{L_1 L_2}$
 D) $M \leq \sqrt{L_1 L_2}$
4. A balanced load of $5+j4$ is connected with delta. What is the impedance per phase of the equivalent star connection?
 A) $5+j4$
 B) $1.66+j1.33$
 C) $15+j12$
 D) $2.5+j2$
5. A circuit with a resistor, inductor and capacitor in series is resonant at f_0 Hz. If all the component values are now doubled, the new resonant frequency is
 A) $2f_0$
 B) Still f_0
 C) $\frac{f_0}{4}$
 D) $\frac{f_0}{2}$
6. A zero mean random signal is uniformly distributed between limits $-a$ and $+a$ and its mean square value is equal to its variance. Then the r.m.s value of the signal is
 A) $\frac{a}{\sqrt{3}}$
 B) $\frac{a}{\sqrt{2}}$
 C) $a\sqrt{2}$
 D) $a\sqrt{3}$
7. The impulse response of a system is $h(t) = t u(t)$. For an input $u(t-1)$, the output is
 A) $\frac{t^2}{2} u(t)$
 B) $\frac{t(t-1)}{2} u(t-1)$
 C) $\frac{(t-1)^2}{2} u(t-1)$
 D) $\frac{t^2-1}{2} u(t-1)$
8. A band-limited signal with a maximum frequency of 5kHz is to be sampled. According to the sampling theorem, the sampling frequency in kHz which is not valid is
 A) 5
 B) 12
 C) 15
 D) 20

9. Assuming zero initial condition, the response $y(t)$ of the system given below to a unit step input $u(t)$ is

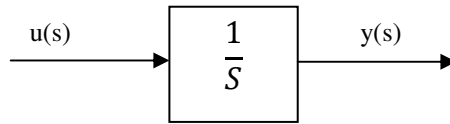

- A) $u(t)$ B) $t u(t)$ C) $\frac{t^2}{2} u(t)$ D) $e^{-t} u(t)$
10. Given $X(z) = \frac{z}{(z-a)^2}$ with $|z| > a$, the residue of $X(z)z^{n-1}$ at $z=a$ for $n \geq 0$ will be
 A) a^{n-1} B) a^n C) na^n D) na^{n-1}
11. Neglecting all losses, the developed torque (T) of a d.c separately excited motor operating under constant terminal voltage, is related to its output power (P) as under
 A) $T \propto \sqrt{P}$ B) $T \propto P$ C) $T^2 \propto P^3$ D) T independent of P
12. The magnetizing current in a transformer is rich in
 A) 3rd harmonics B) 5th harmonics C) 7th harmonics D) 13th harmonics
13. When the supply voltage to an induction motor is reduced by 10% the maximum torque will decrease by approximately.
 A) 5% B) 10% C) 20% D) 40%
14. The angle δ in the swing equation of a synchronous generator is the
 A) Angle between stator voltage and current
 B) Angular displacement of the rotor with respect to the stator
 C) Angular displacement of the stator mmf with respect to a synchronously rotating axis
 D) Angular displacement of an axis fixed to the rotor with respect to a synchronously rotating axis
15. Which type of motor is most suitable for computer printer drive?
 A) Reluctance motor B) Hysteresis motor
 C) Shaded pole motor D) Stepper motor
16. When is the Ferranti effect on long overhead lines experienced?
 A) The line is lightly loaded B) The line is heavily loaded
 C) The line is fully loaded D) The power factor is unity
17. Bundled conductors are used for EHV transmission lines primarily for reducing the
 A) Surge impedance of the line B) Corona loss
 C) Voltage drop across the line D) I^2R losses
18. A 10kVA, 400V/200V single-phase transformer with 10% impedance, draws a steady short circuit current of
 A) 50A B) 150A C) 250A D) 350A

19. An alternator having an induced emf of 1.6 pu is connected to an infinite bus of 1.0 pu. If the bus bar has reactance of 0.6 pu and alternator has reactance of 0.2 pu, what is the maximum power that can be transferred?
 A) 2 pu B) 2.67 pu C) 5pu D) 6pu
20. Which is the main relay for protecting up to 90% of the transmission line length in the forward direction?
 A) Directional over current relay B) Mho relay
 C) Carrier – current protective relay D) Impedance relay
21. For variables heads of near about but less than 30 meters, which types of turbine is used in hydro power stations?
 A) Pelton B) Kaplan C) Francis D) None of these
22. The transfer function of a system is given as $\frac{100}{s^2+20s+100}$
 The system is
 A) An over damped system B) An under damped system
 C) A critically damped system D) An unstable system
23. Introduction of integral action in the forward path of a unity feedback system results in a
 A) marginal stability B) System with no steady state error
 C) System with increased stability margin D) System with better speed of response
24. The eigen-values of the matrix $\begin{bmatrix} a & 1 \\ a & 1 \end{bmatrix}$ are
 A) (a+1),0 B) a, 0 C) (a-1), 0 D) 0, 0
25. A minimum phase unity feedback system has a Bode plot with a constant slope of -20db/decade for all frequencies. What is the value of the maximum phase margin for the system?
 A) 0^0 B) 90^0 C) -90^0 D) 180^0
26. The scale of a voltmeter is uniform. Its type is
 A) Moving iron B) Induction
 C) Moving coil permanent magnet D) Moving coil dynamometer
27. A Kelvin double bridge is best suited for the measurement of
 A) Inductance B) Capacitance C) Low resistance D) High resistance
28. The effect of stray magnetic fields on the actuating torque of a portable instrument is maximum when the operating field of the instruments and the stray field are
 A) Perpendicular B) Parallel C) Inclined at 60^0 D) Inclined at 30^0
29. In a constant voltage transformation (CVT), the output voltage remains constant due to
 A) Capacitor B) Input inductor C) Saturation D) Tapped windings
30. A water boiler at home is switched ON to the ac main supplying power at 230V/50Hz the frequency of instantaneous power consumed by the boiler is
 A) 0 Hz B) 50 Hz C) 100 Hz D) 150 Hz

31. The mobility of an electron in a conductor expressed in terms of
 A) $\text{Cm}^2/\text{V}\cdot\text{sec}$ B) $\text{Cm}/\text{V}\cdot\text{sec}$ C) Cm^2/V D) Cm^2/sec

32. The variation of drain current with gate to source voltage ($I_D - V_{GS}$ Characteristics) of a MOSFET is shown in figure. The MOSFET is

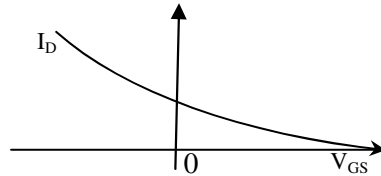

- A) An n-channel depletion mode device
 B) An n-channel enhancement mode device
 C) An p-channel depletion mode device
 D) An p-channel enhancement mode device
33. A low-pass filter with a cut-off frequency of 30Hz is cascaded with a high-pass filter with a cut-off frequency of 20Hz. the resultant system of filters will function as
 A) An all-pass filter B) An all-stop filter
 C) A band stop (band-reject) filter D) A band-pass filter
34. A sinusoidal waveform can be converted to a square waveform by using a
 A) Two stage transistorized over driven amplifier
 B) Two stage diode detector circuit
 C) Voltage comparator based on op-amp
 D) Regenerative voltage comparator circuit
35. An op-amp has a slew rate of $5\text{V}/\mu\text{s}$. The largest sine wave output voltage possible at a frequency of 1MHz is
 A) $10\pi\text{ V}$ B) 5V C) $\frac{5}{\pi}\text{ V}$ D) $\frac{5}{2\pi}\text{ V}$
36. The reduced form of the boolean expression $A[B+C(\overline{AB} + \overline{AC})]$ is
 A) \overline{AB} B) $A\overline{B}$ C) AB D) $AB+B\overline{C}$
37. The AND function can be realized by using only n numbers of NOR gates. What is n equal to?
 A) 2 B) 3 C) 4 D) 5
38. Which of the following counter results in least delay?
 A) Ring counter B) Ripple counter
 C) Synchronous counter D) Asynchronous counter
39. A bulb in a staircase has two switches, one switch being at the ground floor and the other one at the first floor. The bulb can be turned ON and also can be turned OFF by any one of the switches irrespective of the state of the other switch. The logic of switching of the bulb resembles
 A) An AND gate B) An OR gate
 C) A XOR gate D) A NAND gate

40. A memory system has a total of 8 memory chips, each with 12 address lines and 4 data lines. The total size of the memory system is
 A) 16 k bytes B) 32 k bytes C) 48 k bytes D) 64 k bytes
41. A switched mode power supply operating at 20 kHz to 100 kHz range uses _____ as the main switching element
 A) Thyristor B) Triac C) MOSFET D) UJT
42. When the firing angle α of a single-phase, fully controlled rectifier feeding a constant dc current into a load is 30° , the displacement power factor of the rectifier is
 A) 1 B) 0.5 C) $1/\sqrt{3}$ D) $\sqrt{3}/2$
43. A step down chopper is operated in the continuous conduction mode in steady state with a constant duty ratio D. If V_0 is the magnitude of the dc output voltage and if V_s is the magnitude of the dc input voltage, the ratio $\frac{V_0}{V_s}$ is given by
 A) D B) 1-D C) $\frac{1}{1-D}$ D) $\frac{D}{1-D}$
44. When a line commutated converter operates in the inverter mode?
 A) It draws both real and reactive power from the ac supply
 B) It delivers both real and reactive power to the ac supply
 C) It delivers real power to the ac supply
 D) It draws reactive power from the ac supply
45. A three phase semi-converter feeds the armature of separately excited dc motor, supplying a non-zero torque, for a steady state operation, the motor armature current is found to drop to zero at certain instances of time. At such instances, the voltage assumes a value that is
 A) Equal to the instantaneous value of the ac phase voltage
 B) Equal to instantaneous value of the motor back emf
 C) Arbitrary
 D) Zero
46. In a uniform electric field, field lines at equipotential surface
 A) Are parallel to one another B) Intersect at 45°
 C) Intersect at 30° D) Are orthogonal
47. A coil of 300 turns is wound on a non-magnetic core having a mean circumference of 300mm and a cross-sectional area of 300mm^2 . The inductance of the coil corresponding to a magnetizing current of 3A will be (Given that $\mu_0 = 4\pi \times 10^{-7}\text{H/m}$)
 A) $37.68 \mu\text{H}$ B) $113.04 \mu\text{H}$ C) $3.768 \mu\text{H}$ D) $1.1304 \mu\text{H}$
48. If \vec{E} is the electric field intensity, $\nabla(\nabla \times \vec{E})$ is equal to
 A) \vec{E} B) $|\vec{E}|$ C) Null vector D) Zero

49. An electron with velocity \vec{u} is placed in an electric field \vec{E} and magnetic field \vec{B} the force experienced by electron is given by

A) $-e\vec{E}$

B) $e\vec{u} \times \vec{B}$

C) $-e(\vec{u} \times \vec{E} + \vec{B})$

D) $-e(\vec{E} + \vec{u} \times \vec{B})$

50. Where is the Laplace's equation valid?

A) Only in free space

B) Only in conductors

C) Only in charge free dielectric regions

D) Only in cavities bounded on all sides by conducting walls

x-x-x

Electrical & Electronics Engineering(Ph.D.) (1077)

1. A 400 V, 15 kW, 4 pole, 50 Hz, star connected induction motor has full load slip of 4 %. The output torque of the machine at full load is
 A) 1.66 Nm B) 95.50 Nm C) 99.47 Nm D) 624.73 Nm
2. A delta has each element of value $\frac{R}{2}$. The equivalent elements of star circuit will be
 A) $\frac{R}{6}$ B) $\frac{3R}{2}$ C) $3R$ D) $2R$
3. The daily energy produced by a thermal plant is 720 MWh at a load factor of 0.6. What if the maximum demand of the station?
 A) 720 MW B) 432 MW C) 1200 MW D) 50 MW
4. The per unit impedance of the circuit element is 0.15. If the base kV and base MVA are halved, then the new value of the per unit impedance of the element will be
 A) 0.075 B) 0.15 C) 0.30 D) 0.60
5. A 10 kVA, 400/200 V single phase transformer with 10 % impedance draws a steady short circuit line current of
 A) 50 A B) 150 A C) 250 A D) 350 A
6. A two winding ideal transformer having turn ratio of 1:40 has primary resistance value of 8 Ω . For transferring the maximum power to 2 Ω resistor, the number of turns required in the primary winding will be
 A) 120 B) 80 C) 40 D) 20
7. The values of impedances are given in per unit for the network below. Y_{BUS} for the network will be

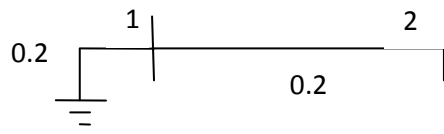

- A) $\begin{bmatrix} 10 & -5 \\ -5 & 5 \end{bmatrix}$ B) $\begin{bmatrix} 10 & -5 \\ -5 & 10 \end{bmatrix}$
- C) $\begin{bmatrix} 10 & -5 \\ 5 & 5 \end{bmatrix}$ D) $\begin{bmatrix} 10 & 5 \\ 5 & 5 \end{bmatrix}$
8. A 100:5 current transformer has secondary winding and lead resistance of 0.20 ohm and secondary burden is 5 VA. The VA output is
 A) 5 VA B) 10 VA C) 7.5 VA D) 2.5 VA

9. The 6 V zener diode shown in figure has zero zener resistance and a knee current of 5 mA. The minimum value of the R so that the voltage across it does not fall below 6 V is

A) 1.2 k Ω B) 75 Ω C) 50 Ω D) 0 Ω

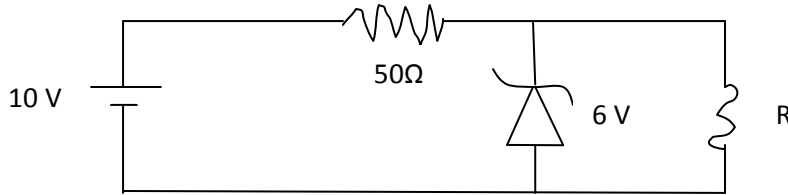

10. The output from a frequency modulation system is
 A) AC voltage
 B) DC voltage
 C) AC as well DC voltage
 D) AC voltage of double magnitude
11. Which of the following devices cannot be used for measuring pressure
 A) Pyrometer B) Strain gauge C) LVDT D) Piezoelectric crystal
12. The current in the primary winding of a current transformer depends upon
 A) Load connected to the system in which the C.T. is installed
 B) Burden of the secondary winding of the transformer
 C) Both burden of the transformer and load connected to the system
 D) None of the above
13. The readings of the 2 wattmeters while conducting a load test are 14.2 kW and -6.1 kW when line voltage of 400 V is applied. The line current is:
 A) 42.76 A B) 43.16 A C) 47.26 A D) 45.34 A
14. A DC supply is connected across a series RLC circuit. Under steady state conditions, the applied DC voltage drops entirely across the following
 A) R only B) R and L only C) C only D) L only
15. A 10 pole, 25 Hz synchronous generator is directly coupled to and driven by 60 Hz synchronous motor. What is the number of pole of synchronous motor?
 A) 12 B) 48 C) 36 D) 24
16. The root mean square value of the voltage defined by $V(t) = 5 + 5 \sin(\omega t + \frac{\pi}{6})$ is
 A) 10 V B) 6.12 V C) 5 V D) 12.5 V

17. In a type A chopper source voltage is 100 V DC. $T_{ON}=200 \mu\text{s}$, $T_{OFF}=150 \mu\text{s}$ and RLE consists of $R=4\Omega$, $L=10\text{mH}$, $E=20\text{V}$. For continuous conduction V_{avg} and I_{avg} are respectively
- A) 62.8 V, 10.71 A B) 50 V, 10.2 A
C) 40.5 V, 15 A D) 50 V, 20.4 A
18. The plug setting multiplier of a negative sequence relay is 0.2 A. The current transformer ratio is 5:1. The minimum value of the line-to-line fault current for the operation of the relay is
- A) 1 Amp B) $\sqrt{3}$ Amp C) $1/\sqrt{3}$ Amp D) 0 Amp
19. The regenerative method of braking is based on that
- A) Back EMF is less than applied voltage
B) Back EMF is equal than applied voltage
C) Back EMF is more than applied voltage
D) Back EMF is zero
20. The value of decimal value $(4523.15)_{10}$ in Hexadecimal is
- A) 1AB1 B) 11BA C) 1BA1 D) 11AB
21. A 3-phase squirrel cage induction motor has a starting current of 7 times the full load current and full load slip of 5 %. If a per unit starting torque of 0.5 is required, then the per unit starting current should be
- A) 4.65 B) 3.16 C) 2.13 D) 3.75
22. The rotor output of the 3-phase induction motor is 15 kW. The rotor current losses at a slip of 4 % will be
- A) 600 W B) 650W C) 700 W D) 625 W
23. A cascade set comprises of two motors with 4 poles and 6 poles respectively. The set is connected to 60 Hz supply. The synchronous speed of the set is
- A) 720 rpm B) 800 rpm C) 180 rpm D) 1000 rpm
24. A DC series motor is accidentally applied to a single phase AC supply. The torque produced will be
- A) Zero B) Oscillating
C) Pulsating and unidirectional D) Steady and unidirectional
25. Possible 3-phase to 3 phase transformer connection for parallel operation is
- A) Delta- Star to Delta – Star B) Delta- Delta to Delta – Star
C) Star- Star to Delta – Star D) Delta- Star to Star-Delta

- 26.** For the same maximum demand, if the load factor is decreased, the cost of generation will
- A) Remain unchanged B) Decrease
C) Increase D) Zero
- 27.** The open loop DC gain of a unity negative feedback system with closed loop transfer function $\frac{s+4}{s^2+6s+13}$ is
- A) 4/13 B) 4/9 C) 4 D) 13
- 28.** If the characteristics equation of a closed loop system is $s^2 + 2s + 2 = 0$, then the system is
- A) Over-damped B) Under-damped
C) Undamped D) Critically damped
- 29.** The gain margin of a system having the loop transfer function $G(s)H(s) = \frac{\sqrt{2}}{s^2+8s}$ is
- A) 0 B) 3 C) 8 D) ∞
- 30.** A linear autonomous system has state variable description $\dot{x} = Ax$ where x is the two dimensional state and A is the system matrix given by $A = \begin{bmatrix} 0 & 2 \\ 2 & 0 \end{bmatrix}$, the roots of the characteristics equations are
- A) -2 and 2 B) $j2$ and $-j2$ C) -2 and -2 D) 2 and $j2$
- 31.** If the full load slip of a 3-phase, 50 Hz induction motor is 950 rpm, the half load speed will be nearly equal to
- A) 1000 rpm B) 450 rpm C) 2000 rpm D) 975 rpm
- 32.** In an 8085 microprocessor, the contents of the accumulator after the following instructions are executed will become
- XRA A
MVI B, F0 H
SUB B
- A) 01 H B) 0F H C) 10 H D) F0 H
- 33.** Percentage resistance and reactances of a transformer are 1 % and 4 % respectively. The voltage regulations at power factor 0.8 lagging and 0.8 leading would be:
- A) 2.4 % and -0.8 % respectively B) 3.2 % and -1.6 % respectively
C) 2.4 % and -1.6 % respectively D) 4.8 % and -0.8 % respectively
- 34.** If both number of turns and the core length of an inductive coil are doubled, then its self inductance will be
- A) Doubled B) Halved C) Unaffected D) Quadrupled

35. The good effect of corona on overhead lines is to
- Increase the line carrying capacity
 - Increase the power factor due to corona loss
 - Reduces the radio interference from the conductor
 - Reduces the steepness of the surge front
36. A cable has an inductance of 0.22 mH per km and capacitance of 0.202 μ F per km. The surge impedance of the cable is
- 28 Ω
 - 33 Ω
 - 42 Ω
 - 50 Ω
37. If two buses with bus voltages $V_1 = 100\angle 30^\circ$ and $V_2 = 100\angle 0^\circ$ are connected through a line having reactance $j5\Omega$. The real and reactive power transferred by bus 1 respectively will be
- 1000 W and 268 VAR
 - 1000 W and -134 VAR
 - 267.8 W and -57.9 VAR
 - 276.8 W and 57.9 VAR
38. In a semiconductor material doping is done to
- Decrease the large number of charge carriers
 - Change the chemical properties of the semiconductor
 - Make semiconductor less than 100 % pure
 - All the crystal structure of the pure semiconductor
39. The short circuit admittance matrix of a two port network is $\begin{bmatrix} 0 & -2 \\ 2 & 0 \end{bmatrix}$. The two-port network
- Non reciprocal and passive
 - Non reciprocal and active
 - Reciprocal and passive
 - Reciprocal and active
40. Kirchhoff's law is applied to circuits with
- Non linear elements only
 - Linear elements only
 - Linear, non-linear and active elements only
 - Linear, non-linear, active, passive time varying as well as time invariant elements
41. In an RLC series circuit with $R=5\Omega$ and voltage across inductor is double to the voltage across capacitor. For a given frequency of 50 Hz for the supply, the inductance of the coil would be
- 2.14 mH
 - 5.2 mH
 - 31.8 mH
 - 1.32 mH
42. An energy meter has a constant of 50 rev/kWh. If it is connected to a 240 V load drawing a current of 5A at 0.8 pf lag. The speed of the revolution of the disc is
- 2 rpm
 - 4 rpm
 - 6 rpm
 - 8 rpm

43. The armature resistance of a 6 pole lap wound DC machine is 0.05Ω . If the armature is rewound as a wave-winding, what is the armature resistance
 A) 0.45Ω B) 0.30Ω C) 0.24Ω D) 0.15Ω
44. An auto transformer transfers 2 kW power inductively to secondary while supplied a total load of 10 kW. What would be its transformation ratio
 A) 0.6 B) 1.2 C) 0.8 D) 1.8
45. A transistor has a current gain of 0.99 in the CB mode. Its current gain in CC mode will be
 A) 100 B) 1.01 C) 0.99 D) 99
46. The inverse Laplace transform of $\frac{1}{(s+a)^2}$ is
 A) $\frac{e^{at}}{2} \sin at$ B) te^{-at} C) $e^{at} \sin 2at$ D) $1 - te^{-at}$
47. The output wave form V_o will be..... If a triangular wave is applied to an operational amplifier acting as a differentiator
 A) Square wave B) Triangular wave only
 C) Sine wave D) Ramp signal
48. Minimum number of J-K flip-flop needed to construct a BCD counter is
 A) 5 B) 3 C) 2 D) 4
49. TRIACs cannot be used in AC voltage regulator for a
 A) Resistive Load B) Back emf load
 C) Inductive load D) R-L Load
50. A boost regulator has an input voltage of 5 V and the average output voltage of 15 V. the duty cycle is
 A) $3/2$ B) $2/3$ C) $5/2$ D) $1/3$

x-x-x

English(1077)

1. The term “ magic realism” originated from:-
 - (A) The German *MagischerRealismus*
 - (B) The French *MagicoRealismo*
 - (C) The Spanish *MagischeRealismus*
 - (D) The Dutch *MagischusRealisme*
2. Which of the following writers did make this statement about India:- “ And if I were to ask myself from what literature, we, who have been nurtured almost exclusively on the thoughts of Greeks and Romans, and of Semitic race, the Jewish, may draw the corrective which is most wanted in order to make our inner life more perfect, more comprehensive, more universal, in fact more truly human a life...again I should point to India”:-
 - (A) Edward Said
 - (B) Hegel
 - (C) Friedrich Max Muller
 - (D) Rudyard Kipling
3. Which of the following statements is true of Cultural Studies:-
 - (A) Cultural Studies originated at Cambridge in 1964
 - (B) Raymond Williams and F. R. Leavis founded the Birmingham(UK) Centre for Contemporary Cultural Studies at University of Birmingham in 1964
 - (C) In 2002, the administrative authorities of University of Birmingham(UK) suddenly announced the disestablishment of the Department of Cultural Studies and Sociology(CSS)
 - (D) Cultural Studies has a quite dogmatic and rigid theoretical framework
4. Which of the following writers did make this statement about rural life in India: “ We must not forget that this undignified ,stagnatory, and vegetativelife , that this passive sort of existence , evoked on the other part, in contradiction, wild, aimless, unbounded forces of destruction, and rendered murder itself a religious rite in Hindostan”
 - (A) Immanuel Kant
 - (B) J.S. Mill
 - (C) James Mill
 - (D) Karl Marx
5. Which of the following critics associated with postcolonialism does consider Gandhi as the first Green politician: -
 - (A) Edward Said
 - (B) Gayatri C. Spivak
 - (C) Robert J.C.Young
 - (D) Homi Bhabha
6. Which of the following thinkers did consider the life and ideas of the Hindus as an “unbroken superstition” because “ among them all is reverie and consequent reverie”:-
 - (A) Hegel
 - (B) Fredric Jameson
 - (C) Terry Eagleton
 - (D) Homi Bhabha

7. Which of the following Indian writers did write *The Future Poetry*, the first book on the theory of poetry published in India:-
 (A) Rabindranath Tagore (B) Sri Aurobindo
 (C) Sarojini Naidu (D) Nissim Ezekiel
8. *The Meaning of India* is written by:-
 (A) R.K. Narayana (B) Mulk Raj Anand
 (C) Raja Rao (D) Salman Rushdie
9. The novel *Em and the big Hoom* is written by:-
 (A) Nadine Gordimer (B) Jerry Pinto
 (C) Margaret Atwood (D) Martin Amis
10. *Other Asias* is written by:-
 (A) Gayatri Chakravorty Spivak (B) Robert J.C. Young
 (C) Noam Chomsky (D) Amartya Sen
11. *Being Different: An Indian Challenge to Western Universalism* is written by:-
 (A) Arjun Appadurai (B) Asif Dirlik
 (C) Amitav Ghosh (D) Rajiv Malhotra
12. The subtitle of the book- *The Politics of Postcolonialism*, that offers, inter alia, “some kind of defence against accusations of eurocentrism and location politics”, is:-
 (A) *Nation, Empire, Resistance* (B) *Empire, Resistance, Nation*
 (C) *Empire, Nation, Resistance* (D) *Culture, Nation, Empire*
13. Which of the following statements about the affective fallacy is true:-
 (A) The term was coined by Cleanth Brooks in 1925.
 (B) It is said to be a critical error of analysing a work of art in terms of ‘ its results in the mind of the audience’.
 (C) It marks the ‘affective turn’ in criticism, which represents an attempt to turn away from the poststructuralist ‘linguistic turn’.
 (D) The term was defined by Wimsatt and Beardsley in *Practical Criticism*
14. “Abjection”- the psychoanalytic concept, which is used to explain the formation and maintenance of subjectivity, was developed by:-
 (A) Julia Kristeva (B) Jacques Lacan
 (C) Jung (D) Freud
15. Allegory comes from Greek- ‘ allegoria’ meaning:-
 (A) Creating an illusion (B) To be in an illusion
 (C) Speaking otherwise (D) Writing in disguise
16. The term ‘contrapuntal reading’ was coined by:-
 (A) Edward Said (B) Antonio Gramsci
 (C) Jacques Derrida (D) Michel Foucault

17. Michel Foucault delivered a lecture on literary theory at College de France on 22 February 1969. This lecture is considered as his response to Roland Barthes's essay "The Death of the Author". The title of this lecture is known as :-
 (A) "Re-birth of the Author" (B) "After-life of the Author"
 (C) "The Rise of the Reader" (D) "What is an Author?"
18. *Vakyapadiya*, a discourse on the theory of language and meaning was written by:-
 (A) Bhartrihari (B) Rajshekher
 (C) Nagarjuna (D) Dharmakirti
19. "Pure autonomy is a dream of evil"- is an important idea that is elaborated with examples culled from literary works and modern history in the book *On Evil. On Evil* is written by:-
 (A) Fredric Jameson (B) Paul de Man
 (C) Terry Eagleton (D) Raymond Williams
20. In order to systematically and rationally combat a "currently fashionable postmodernist/poststructuralist/social-constructivist discourse- and more generally a penchant for subjectivism, which is...inimical to the values and future of the Left", Alan Sokal wrote a book entitled:-
 (A) *Beyond the Hoax: Science, Philosophy and Culture*
 (B) *Beyond the Borders: Academic Freud in Contemporary Theory*
 (C) *Transgressing the Boundaries: A Report on Interdisciplinary Studies*
 (D) *Subverting the Gaze: Society, Philosophy and Culture*
21. The term 'Dark Comedy' was coined by:-
 (A) A.C. Bradley (B) Aristotle
 (C) J.L. Styan (D) Bertolt Brecht
22. The book *The Environmental Imagination* (1995) was written by:-
 (A) Vandana Shiva (B) Cheryl Glotfelty
 (C) Harold Fromm (D) Lawrence Buell
23. Which of the following critics introduced the term 'focalization' in the field of narratology:-
 (A) Gerard Genette (B) Roland Barthes
 (C) Hayden White (D) Henry James
24. The term 'foregrounding' is the English rendering of :
 (A) The French word 'foreaugruse' (B) The German word 'forschgrundt'
 (C) The Italian word 'forigroundio' (D) The Czech word 'aktualisace'
25. Which of the following Indian theorists did write *Vakroktijivitam*:-
 (A) Mammata (B) Acharya Vishwanath
 (C) Udbhata (D) Kuntaka

26. The name of the classical Tamil discourse (already translated into English) on Phonology, Morphology, Syntax, Semantics and Poetics , which also bears a resemblance to Bharata's *Natyashastra*, is :-
 (A) *Tolkappiyam* (B) *Manimekhalai*
 (C) *Silapaddikaram* (D) *Tirukkural*
27. Raja Rao wrote an important biography of Mahatma Gandhi entitled:-
 (A) *From Mohan to Mahatma: Life of Gandhi*
 (B) *Bapu Reconsidered: Life of Mahatma Gandhi*
 (C) *Gandhi: A Life of Ethical Action*
 (D) *The Great Indian Way: A Life of Mahatma Gandhi*
28. Which of the following women writers did emphatically assert that , “ Perhaps a mind that is purely masculine cannot create, any more than a mind that is purely feminine...” :-
 (A) Virginia Woolf (B) Mary Wollstonecraft
 (C) Simone de Beauvoir (D) Margaret Atwood
29. *Me and My Plays* is written by:-
 (A) Girish Karnad (B) Vijay Tendulkar
 (C) Badal Sarkar (D) Mahesh Dattani
30. *Hindu: A Novel* is written by an eminent Dalit writer. The name of the Dalit writer is:-
 (A) Arjun Dangle (B) Namdeo Dhasal
 (C) Sharankumar Limbale (D) Baburao Bagul
31. *The Vegetarian*, a novel that critiques the contemporary modernity and its many hypocrisies is written by:-
 (A) Hang Kang (B) Margaret Atwood
 (C) Alice Munro (D) Chinua Achebe
32. *Exile: A Memoir* is written by:-
 (A) Taslima Nasrin (B) Edward Said
 (C) Salman Rushdie (D) Imtiaz Dharker
33. *The Schooldays of Jesus* is written by:-
 (A) Ian McEwan (B) V S Naipaul
 (C) J M Coetzee (D) Alan Paton
34. *Omeros* is a :-
 (A) Novel of protest against imperialism written by Caribbean writer Derek Walcott
 (B) An epic poem written by Caribbean writer Derek Walcott
 (C) A verse drama by Derek Walcott
 (D) An anthology of short stories by Derek Walcott
35. C. P. Cavafy was a/an:-
 (A) Egyptian Greek poet (B) Palestinian poet

- (C) Syrian American poet (D) Egyptian American poet
36. The name of the first woman to write poetry in English from Pakistan is:-
 (A) Razia Khan (B) Meherunnisa Parvez
 (C) Abida Rasheed (D) Maki Kureshi
37. At University of Geneva, where Ferdinand de Saussure was offered a professorship in 1892, he continued to:-
 (A) Lecture on Sanskrit and Indo-European for the remainder of his life
 (B) Lecture on French symbolism and anthropology for the remainder of his life
 (C) Lecture on German philosophy of language and meaning
 (D) Lecture on French and German schools of linguistics
38. The subtitle of Amitav Ghosh's recently published book, *The Great Derangement* is:-
 (A) *Cultural Imperialism Today*
 (B) *Climate Change and the Unthinkable*
 (C) *The Politics of the Impossible*
 (D) Culture and Society in a Globalized World
39. The word 'nihilism' was coined by :-
 (A) Turgenev (B) Nietzsche
 (C) Schopenhauer (D) Thomas Hardy
40. Which of the following is not a critic associated with the Prague School:-
 (A) Roman Jakobson (B) Boris Eikenbaum
 (C) Viktor Shklovsky (D) Franz Bopp
41. Which of the following modern poets did write the lines:-
 "And do not think of the fruit of action./ Fare forward./....So Krishna, as when he admonished Arjuna/ on the field of battle."
 (A) W.B. Yeats (B) Ezra Pound
 (C) T.S.Eliot (D) Ted Hughes
42. Which of the following is the source from which T.S.Eliot (in his poem- *The Waste Land*) borrowed the famous utterances –"Datta"(Give), "Dayadhvam" (Sympathize), "Damyata"(Control):-
 (A) *The Bhagavadgita* (B) *Ishavasyopanishad*
 (C) *Kathopanishad* (D) *Brihadaranyaka Upanishad*
43. Which of the following novels was awarded the Man Booker International Prize 2017:-
 (A) *A Horse Walks Into a Bar* by David Grossman
 (B) *Swing Time* by Zadie Smith
 (C) *The Sellout* by Paul Beatty
 (D) *Bring Up the Bodies* by Hilary Mantel

44. The famous article- “ Notes on deconstructing “the popular” was written by:-
 (A) Roland Barthes (B) Stuart Hall
 (C) Raymond Williams (D) Michel Foucault
45. Which of the following Indian writers said that it is “only when British critics begin to call Indian-English speech ‘Pidgin-English’ that the Indian words in English begin to look ludicrous, incongruous and lacking in good taste.”:-
 (A) R.K.Nraranayan (B) Raja Rao
 (C) Mulk Raj Anand (D) Anita Desai
46. The play, *The Doldrums* was written by :-
 (A) Nissim Ezekiel (B) Mahesh Dattani
 (C) Girish Karnad (D) Asif Currimbhoy
47. *I Speak for the Devil* is written by:-
 (A) Imtiaz Dharker (B) Margaret Atwood
 (C) Sujata Bhatt (D) Makarand Parranjape
48. The influential essay “What Is an Author?” is written by:-
 (A) Roland Barthes (B) Michel Foucault
 (C) Cleanth Brooks (D) Antonio Gramsci
49. Which of the following novelists did adapt the term “epiphany” to secular experience in fiction “to signify the experience of a sudden radiance and revelation that occurs in the act of perceiving a commonplace object” :-
 (A) Marcel Proust (B) Kafka
 (C) Henry James (D) James Joyce
50. When a writer uses the term “ten hands” for ten workers, she/he is using the figure of speech called:-
 (A) Synecdoche (B) Personification
 (C) Prosopopeia (D) Dead Metaphor

Environment Studies(1077)

1. Maximum carbon in the world is found in
 - A) Glaciers
 - B) Forests
 - C) Oceans
 - D) Coal Mines
2. Which of the following statements are true regarding Soda Lake?
 1. Soda lakes are highly acidic lakes.
 2. Soda lakes are highly productive ecosystems.
 3. A critical geological condition for the formation of Soda Lake is the absence of soluble calcium or magnesium.
 4. Lonar and Sambhar lakes are examples of Soda lakes in India.
 - A) 1, 2 & 3 only
 - B) 1 & 4 only
 - C) 2, 3 & 4 only
 - D) 1, 3 & 4 only
3. Turpentine oil used in medicine' is obtained from
 - A) Willow
 - B) Chir Pine
 - C) Salix
 - D) Acacia
4. Earth is said to be divided into
 - A) 12 time zones
 - B) 24 time zones
 - C) 18 time zones
 - D) 30 time zones
5. White lung cancer is caused by
 - A) Silica
 - B) Asbestos
 - C) Textiles
 - D) Paper
6. The Himalayan Yew Tree in the Himalayan region that has cancer curing properties is facing near extinction. The reason for this can be
 - A) A widespread attack of fungus on these trees
 - B) Introduction of other invasive species
 - C) Over exploitation
 - D) Construction of new dams that has led to submersion of vast areas
7. Consider the following lakes:
 - I. Sasthamkotta Lake
 - II. Vembanad Lake
 - III. Ashtamudi Lake
 - IV. Vellayani Lake.

Which if the following statements are correct regarding the above mentioned lakes

1. All these lakes are located in Kerala
2. Exactly three lakes are located in Kerala
3. All these lakes are Ramsar sites
4. Exactly three lakes are Ramsar sites

A) 1 & 4 only B) 2 & 3 only C) 1 & 3 only D) 2 & 4 only

8. Beryllium fumes are emitted from

A) Auto exhaust B) Fluorescent lamp industry
C) Thermal power plant D) Fertilizer industry

9. Windrow is a method of solid waste disposal by

A) Secure landfill B) Sanitary landfill C) Composting D) Incineration

10. Ziegler process

A) Produces high density polyethylene B) Uses No catalyst
C) Produces low density polythene D) Employs very high pressure

11. For the purpose of coastal regulation, Coastal regulation Zone 2011 notification states that the coastal zone is

1. 500 m on the landward side from high tide line.
2. 500 m on the landward side from low tide line.
3. 12 nautical miles on the seaward side from the high tide line.
4. 12 nautical miles on the seaward side from the low tide line.

A) 2 & 4 only B) 1 & 3 only C) 1 & 4 only D) 2 & 3 only

12. Who among the following first recognized the green house effect

A) Jean-Baptiste Lamarck B) Jean Baptiste Greenhouse
C) Jean Baptiste Fourier D) Jean Baptiste Greenwood

13. Which of the following dams is not on River Narmada?

A) Indira-Sagar Project B) Koyna Power Project
C) Jobat Project D) Maheshwar Hydrel Power Project

14. Mho's scale of hardness is used for the measurement of hardness

A) Scratch B) Indentation C) Dynamic D) Rebound

15. U-235 content in enriched uranium that is normally used in power reactors is approximately

A) 85% B) 50% C) 3% D) 97%

16. The reflectance from a surface is called specular reflection if it follows

A) Snell's law B) Lambert's cosine law

- 28.** In the world of GIS, another term for the property of connectivity is
 A) Proximity B) Location C) Topology D) Boolean identity
- 29.** Which of the following rocks has the lowest porosity?
 A) Shale B) Gravel C) Granite D) Sandstone
- 30.** Which stage of vehicle emission norms is presently applicable in India in Internal Combustion Engine?
 A) Bharat Stage-IV B) Bharat Stage-III C) Bharat Stage- II D) Bharat Stage- I
- 31.** The theme of International Biodiversity Day 2017 was
 A) Biodiversity and Sustainable Tourism
 B) Mainstreaming Biodiversity; Sustaining People and their Livelihoods
 C) Biodiversity for Sustainable Development
 D) Island Biodiversity
- 32.** Which of the following is not a theory of environmental ethics?
 A) Anthro-centricism B) Bio-centricism
 C) Ethno-centricism D) Eco-centricism
- 33.** Which of the following greenhouse gasses has the greatest heat-trapping ability per molecule?
 A) Chlorofluorocarbon B) Methane
 C) Carbon dioxide D) Nitrous oxide
- 34.** What kind of chemical problem exists in a soil that has white crusts where water evaporates?
 A) Sodidity B) Low pH C) Salinity D) High pH
- 35.** The highest seismic domain in India is in
 A) The Himalayas B) The Dharwar Craton
 C) The Western Ghats D) The Indo-gangetic plains
- 36.** In what range of soil pH is phosphorous generally most available to the plants?
 A) 2.0-3.0 B) 4.0-5.0 C) 5.5-7.0 D) 7.0-8.5
- 37.** The average trophic efficiency of transfer of energy from one trophic level to the higher trophic level is called
 A) Lindeman’s trophic efficiency rule B) Exploitation efficiency
 C) Assimilation. Efficiency D) Gross primary production

38. Halon-1301 is a
A) Refrigerant B) Solvent C) Fire extinguisher D) Surfactant
39. Major aerosol pollutant in jet plane emission is
A) Sulphur dioxide B) Carbon monoxide C) Methane D) Fluorocarbon
40. Skin diseases, eye infections and diarrhoea are examples of
A) Water-borne diseases B) Water-washed diseases
C) Water-stress diseases D) Anti-water diseases
41. Spacing of contour lines depend on
A) Steepness B) Altitude C) Area D) Elevation
42. In a pond ecosystem where production is greater than respiration ($P/R > 1$) is termed as
A) Limnetic Zone B) Profundal Zone C) Benthic Zone D) Tidal Zone
43. Lincoln Index is used to measure
A) Population Size B) Population Mortality Rate
C) Population Natality Rate D) Population Density
44. Amongst the following which one does not belong to EIA process?
A) Developing the EMS auditing procedures
B) Suggesting the mitigation measures
C) Identification, prediction and assessment of the impacts
D) Establishment of baseline environmental conditions
45. Which one of the following pairs in mismatched?
A) Tundra – permafrost B) Coniferous forest - evergreen trees
C) Savanna - acacia trees D) Prairie – epiphytes
46. Which of the following is an indicator of Air pollution?
A) Fungi B) Lichen C) Bacteria D) Algae
47. Which of the following element do many scientists believe can provide an unlimited source of clean energy?
A) Hydrogen B) Helium C) Selenium D) Oxygen
48. Which of these is a limiting nutrient in fresh water system?
A) Nitrogen B) Calcium
C) Phosphorous D) Nitrogen and phosphorous

49. Geothermal gradient in earth is

- A) Uniform throughout
- B) Higher in mid oceanic ridges
- C) Higher in sub-duction zone
- D) Higher in continental lithosphere

50. Which of the following is not correctly matched?

- A) World Environment Day 5th of June
- B) World Water Day 22nd of July
- C) World Biodiversity Day 22nd of May
- D) World Earth Day 22nd of April

x-x-x

- C) a-iv, b-iii, c-i, d-ii
D) a-iii, b-iv, c-i, d-ii
45. The chromatographically separated substances can be quantified directly by using:
A) Fluorimetry
B) Densitometry
C) Colorimetry
D) Radiometry
46. Which one of the followings is an irritant?
A) Aconitine
B) Brucine
C) Cannabinoid
D) Calotropin
- 47..... is a spinal poison:
A) HCN
B) Aconite
C) Yellow Oleander
D) Strychnine
48. The term NCR in questioned document examination stands for which of the following:
A) No carbon required
B) No copy repeat
C) No comparison required
D) No crossing required
49. A plastic explosive "Kirkee" is essentially the following explosive:
A) 2, 4, 6-Trinitrotoluene
B) Cyclo Trimethylene Trinitramine
C) 2, 4, 6-Trinitrophenol
D) Trinitrophenyl methyl Nitramine
50. Match the following:
- | (Name) | (Characteristic feature) |
|-------------------|---------------------------------|
| a. PETN | i. Smokeless propellant powder |
| b. Cordite | ii. Secondary high Explosive |
| c. Lead Azide | iii. Semi-smokeless powder |
| d. Lesmoke powder | iv. Incinerating high explosive |
- A) a-iv, b-iii, c-ii, d-i
B) a-iii, b-i, c-iv, d-ii
C) a-ii, b-i, c-iv, d-iii
D) a-iii, b-iv, c-i, d-ii

French(1077)

1. *Le Mare au diable* est écrit par
A) François Mauriac
B) George Sand
C) Céline
D) George Simenon
2. Le Prix Goncourt est attribué chaque année à la meilleure œuvre
A) Musicale
B) Littéraire
C) Cinématographique
D) Architecturale
3. Qui a écrit *L'Amant* ?
A) Simone de Beauvoir
B) Simone Veil
C) Marguerite Duras
D) Marguerite Yourcenar
4. Quelle ville française est surnommée la *Ville rose* :
A) Rouen
B) Bordeaux
C) Lyon
D) Toulouse
5. Léopold Senghor est un écrivain francophone d'origine
A) Sénégalais
B) Marocain
C) Tunisien
D) Egyptien
6. Dans le domaine artistique, à la fin du 19^e. siècle le terme *les nabis* utilisé pour certains peintres signifie :
A) Nobles
B) Purs
C) Noirs
D) Prophètes
7. C'est un chanteur d'origine belge :
A) Jean-Jacques Goldman
B) Jacques Brel
C) Jacques Higelin
D) Jacques Douais
8. Chassez l'intrus :
A) Necker
B) Marie Antoinette
C) Camille Desmoulins
D) Louis XIV
9. « *Rien ne sert de courir ; il faut partir à point* » ... est tiré de la fable :
A) L'Amour et la Folie
B) Le Chêne et le roseau
C) Le Lièvre et la tortue
D) Les deux pigeons
10. Lequel des sons n'est pas une semi-consonne :
A) [ʏ]
B) [w]
C) [ʁ]
D) [j]
11. Complétez : « *Heureux comme un _____* »
A) Beau chien
B) Oiseau
C) Bébé
D) Poisson dans l'eau
12. *La Môme* est le surnom donné à quelle chanteuse :
A) Barbara
B) Rita Mitsouko
C) Edith Piaf
D) Françoise Hardy

13. Le Dadaïsme provient du mot *dada* qui signifie dans le langage enfantin :
- A) Grand-père
B) Cheval
C) Chien
D) Dûr
14. La trilogie de Marcel Pagnol :
- A) *Marie, Fanny et Cécile*
B) *Marius, Fanny et César*
C) *Marius, Fabius et César*
D) *Maria, Fanny et Césaire*
15. [f] est une consonne
- A) Fricative, labiodentale, sourde
B) Fricative, labiodentale, sonore
C) Fricative, sifflante, sonore
D) Fricative, chuintante, sourde
16. « Seau », « Sceau », « Saut », « sot » sont
- A) Des antonymes
B) Des synonymes
C) Des homophones
D) Des homographes
17. Qui a dit- « Vienne la nuit sonne l'heure
Les jours s'en vont je demeure
- A) Guillaume Apollinaire
B) Blaise Cendrars
C) Gérard de Nerval
D) Victor Hugo
18. Laquelle de ces chansons n'a pas été chantée par Jacques Brel? :
- A) « ne me quitte pas »
B) « Quand on n'a que l'amour »
C) « Le plat pays »
D) « Le parapluie »
19. Laquelle de ces œuvres n'a pas été écrite par Guy de Maupassant ? :
- A) *Bel Ami*
B) *Le Horla*
C) *Pierre et Jean*
D) *Paul et Virginie*
20. *Le Contrat social* est une œuvre de
- A) Voltaire
B) Montesquieu
C) Rousseau
D) L'Abbé Prévost
21. Les expressions comme « silences éloquentes », « réalité virtuelle », douce violence » sont des
- A) Euphémismes
B) Oxymores
C) Litotes
D) Métaphores
22. Qui a dit- « Le poète est semblable au prince des nuées
Qui chante la tempête et se rit de l'archer »? :
- A) Charles Baudelaire
B) Guillaume Apollinaire
C) Arthur Rimbaud
D) Alfred de Vigny
23. La phonologie étudie
- A) La fonction des consonnes
B) La face matérielle des sons
C) Le signifiant en relation avec le signifié
D) Les sons selon le point d'articulation
24. La première personne du présent de l'indicatif du verbe « vaincre » :
- A) Je vains
B) Je vains
C) Je vains
D) Je vainq

25. « He plays a good game of chess » traduit comme « Il joue bien aux échecs » est un cas de
 A) Equivalence B) Transposition
 C) Etoffement D) Adaptation
26. Chamonix est une
 A) Pièce de théâtre B) Station de sports d'hiver
 C) Vallée à la frontière Belge D) Vallée au nord de France
27. Dans quel film Catherine Deneuve a-t-elle joué ?
 A) Camille Claudel B) Indochine
 C) Quatre cents coups D) La femme qui pleure
28. *Le Penseur* est une sculpture de
 A) Auguste Rodin B) Michel-Ange
 C) Bernard Palissy D) Leonardo da Vinci
29. Il a créé des romans scientifiques comme *Vingt mille lieues sous les mers* :
 A) Antoine de Saint Exupéry B) Jules Verne
 C) Emile Zola D) Edmond Rostand
30. Mettez au style indirect la phrase :
 Il a crié : « J'ai réussi à mon examen »
 A) Il a crié qu'il a réussi à son examen
 B) Il avait crié qu'il a réussi à son examen
 C) Il a crié qu'il avait réussi à son examen
 D) Il avait crié qu'il avait réussi à son examen
31. Philosophe de l'Absurde, il a reçu le prix Nobel en 1957 :
 A) Sartre B) Camus
 C) Beckett D) Ionesco
32. Homme politique sous la Révolution française, il a été assassiné dans sa baignoire. Il avait une maladie de peau :
 A) Marat B) Robespierre
 C) Rousseau D) Napoléon
33. Les Pyrénées se trouvent entre :
 A) La France et l'Italie B) La France et Belgique
 C) La France et l'Espagne D) La France et l'Allemagne
34. C'est une fête pendant laquelle on fait des défilés de Carnaval, les enfants se déguisent, on fait des crêpes.
 A) La fête nationale B) Mardi Gras
 C) Noël D) La fête des Mères
35. Attention admirative et exclusive portée à soi-même s'appelle :
 A) Narcissisme B) Point de vue
 C) Héroïsme D) Fantastique

36. Allégorie est :
- A) La personnification d'une idée abstraite B) L'animation des forêts
C) La comparaison intertextuelle D) L'allusion aux animaux
37. Dans un film, un spectacle ou un récit, le moment ou passage de nature à faire naître un sentiment d'attente angoissé s'appelle :
- A) Temporalité B) Inconscience
C) Suspense D) Effet de réel
38. Le brie est un fromage de :
- A) Suisse B) Belgique
C) France D) Allemagne
39. Qui a dit « Science sans conscience n'est que ruine de l'âme » :
- A) Rabelais B) Hugo
C) Sartre D) Voltaire
40. « L'eau bout à 100° » dans cette phrase le présent exprime :
- A) Une habitude B) Une vérité générale
C) Une narration D) Un futur proche
41. L'impressionnisme est un mouvement artistique auquel appartient :
- A) Picasso B) Dali
C) Monet D) David
42. À quel courant littéraire appartient Jean-Paul Sartre :
- A) Réalisme B) Naturalisme
C) Existentialisme D) Symbolisme
43. De quelle période date *La Chanson de Roland* :
- A) XVIIe. siècle B) Moyen Age
C) XVIIIe. siècle D) XIXe. siècle
44. La ludique dans la pédagogie se base sur :
- A) La grammaire B) Les jeux
C) Le vocabulaire technique D) La linguistique
45. On associe la Nouvelle Vague avec quel domaine ? :
- A) La littérature B) La musique
C) Le cinéma D) La peinture
46. Le schéma de communication de Jakobson a :
- A) 4 éléments B) 3 éléments
C) 6 éléments D) 7 éléments
47. *Faux amis* en traduction veut dire :
- A) Des amis qui donnent une fausse traduction
B) Des mots qui sont des antonymes
C) Des mots qui sont des synonymes
D) Des mots qui se ressemblent par la forme mais dont le sens varie

- 48.** Dans quel film Gérard Depardieu a-t-il joué le rôle du sculpteur Rodin :
- A) Camille Claudel
 - B) Et Dieu créa la femme
 - C) Cyrano de Bergerac
 - D) Le Dernier métro
- 49.** La grammaire explicite est utilisée dans la méthode:
- A) Communicative
 - B) Traditionnelle
 - C) Audio-visuelle
 - D) Audio-orale
- 50.** Qui a dit – « Philosophe, c'est apprendre à mourir » ?:
- A) Descartes
 - B) Pascal
 - C) Montaigne
 - D) Montesquieu

x-x-x

Gandhian Studies(M.Phil. & Ph.D.) (1077)

1. M. K. Gandhi's ancestral House is now known as:
A) Birla House B) Gandhi House C) Kirti Mandir D) Swaraj Bhawan
2. The number of Children of Putlibai was:
A) Two B) Three C) Four D) Six
3. M.K. Gandhi went to South Africa for the first time in the year:
A) 1887 B) 1888 C) 1891 D) 1893
4. Kaba Gandhi was M.K. Gandhi's:
A) Father B) Grand Father
C) Great Grand Father D) Cousin
5. 'God did not want me to eat today', was the statement of:
A) Kasturbai B) Putlibai C) Rambha D) Miraben
6. Who out of the following suggested Gandhi to chant Rama Nama to save him from ghosts in his childhood?
A) Ladha Maharaj B) Putlibai C) Rambha D) Kasturbai
7. Which of the following plays left a deep impression on Gandhi in his Childhood?
A) Harish Chandra B) Shrawan Kumar
C) Shakuntla D) Both (A) and (B)
8. M.K. Gandhi passed his Matriculation Examination in the year:
A) 1885 B) 1887 C) 1888 D) 1889
9. M.K. Gandhi studied Law at:
A) London B) Natal C) Rajkot D) Durban
10. Gandhi's Childhood friend Uka belonged to the following community:
A) Parsi B) Muslim C) Untouchables D) Christian
11. Identify M.K. Gandhi's eldest brother:
A) Karsandas B) Laxmidas C) Tulsidas D) Maganlal
12. M.K. Gandhi confessed his guilt of stealing and smoking and in this respect wrote a letter to:
A) His Mother B) His Father
C) His Eldest Brother D) His Cousin
13. While going to study Law, Gandhi carried with him a letter of introduction for:
A) P.J. Mehta B) Kevalram C) Mav ji Dave D) Virchand Gandhi
14. Identify the author of Unto This Last:
A) Henry David Thoreau B) John Ruskin
C) John Galtung D) M.K. Gandhi

15. Gandhi was invited to South Africa by:
 A) Raichandra Bhai
 B) Gopalkrishan Gokhale
 C) Dada Abdulla & Co.
 D) Sheth Kamlakant Jhaveri
16. The first day, the Judge in the court in South Africa asked Gandhi to :
 A) Change his dirty shoes
 B) Show his Licence
 C) Change his dress
 D) Takeoff his turban
17. Natal Indian Congress was founded in:
 A) 1893
 B) 1894
 C) 1895
 D) 1896
18. M.K. Gandhi raised his voice in South Africa against:
 A) Employment Laws
 B) Dress Code
 C) Racial Discrimination
 D) Property Laws
19. Gandhi started his Satyagraha Movement in South Africa in the year:
 A) 1893
 B) 1896
 C) 1906
 D) 1908
20. Gandhi's Dandi March was associated with:
 A) Kheda
 B) Salt
 C) Bardoli
 D) Onion
21. Gandhi took the Oath of Brahmacharya in:
 A) 1904
 B) 1906
 C) 1908
 D) 1910
22. Gandhi's son Harilal accepted Islam in:
 A) 1930
 B) 1932
 C) 1936
 D) 1938
23. Who was Gandhi's first Satyagrahi?
 A) Vinoba Bhave
 B) Jawaharlal Nehru
 C) Sardar Patel
 D) J.B. Kripalani
24. Who served as Private Secretary to Gandhi?
 A) Vinoba Bhave
 B) Pyarelal
 C) Jamunalal Bajaj
 D) J.B. Kripalani
25. Kasturba died in detention at:
 A) Yeravada Jail
 B) Ahmadnagar Fort
 C) Agakhan Palace
 D) Sabarmati Jail
26. Kasturba's Samadhi lies at:
 A) Rajghat
 B) Sevagram Ashram
 C) Sabarmati Ashram
 D) Agakhan Palace
27. The Services of Gandhi were secured by Dada Abdulla & Co. initially for a period of:
 A) Six Months
 B) Nine Months
 C) One Year
 D) Two Year
28. Who one out of following wanted to convert Gandhi to Christianity in South Africa?
 A) William Godfrey
 B) A.W. Baker
 C) Kallen Bach
 D) Henry Polak

29. Gandhi started his first Satyagraha in India at:-
 A) Bardoli B) Khela C) Ahmadabad D) Champaran
30. Bardoli Satyagraha occurred in:-
 A) 1922 B) 1928 C) 1930 D) 1932
31. The following associate of Gandhi was involved during the Kheda Satyagraha:-
 A) Dr. Rajendra Prasad B) Jawaharlal Nehru
 C) Sardar Vallabh Bhai Patel D) Motilal Nehru
32. After how many days of strike was the settlement reached between the Ahmadabad Textile Mill Owners and the Labourers?
 A) 10 B) 15 C) 21 D) 25
33. The famous Peasant Struggle with the title ‘Dungli Chor’ (onion thief) occurred at:-
 A) Kheda B) Bardoli C) Champaran D) Ahmadabad
34. Who persuaded Gandhi to visit Champaran regarding forced plantation of Indigo?
 A) Baba Rajendra Prasad B) Rajkumar Shukla
 C) Jayaprakash Narain D) Jawaharlal Nehru
35. Poona Pact was signed between Gandhi and Dr. B.R. Ambedkar on:-
 A) 15th August, 1930 B) 15th August, 1932
 C) 24th September, 1932 D) 24th September, 1930
36. Gandhi learnt the first lesson of Non-violence from his:
 A) Mother B) Father C) Sister D) Wife
37. Gandhi’s Sarvodaya reflects his belief in:
 A) Communism B) Socialism C) Regionalism D) Casteism
38. Gandhi was called a “half naked Faquir” by:
 A) Mountbatten B) Winstin Churchill
 C) Ramsay Mac Donald D) Lord Wavell
39. Gandhi offered fast in Yervada Jail in 1933 for:
 A) Communal Harmony B) Vykom Satyagrahis
 C) Ahmadabad Mill Workers D) Removal of Untouchability
40. Gandhi’s Samadhi is known as :
 A) Shantivan B) Veerbhoomi C) Rajghat D) Shakti Sthal
41. Affectionately Gandhi called Deshbandhu to one of the following:-
 A) C.R. Das B) Thakkar Bapa C) Kaka Kalelkar D) J.C. Kumarappa
42. To Gandhi ‘Bread Labour’ means:
 A) Earnings of a person by selling of Bread
 B) Labour working in the Agricultural Sector
 C) Everyone must labour with his body for a few hours daily
 D) The price of the Bread purchased from the market

43. According to Gandhi "Swaraj" means:-
 A) Freedom from all restraints
 B) Freedom for the weakest in the country
 C) Rule of majority
 D) Freedom from foreign rule
44. Identify the correct match:
 A) The story of Gandhi : Louis Fischer
 B) Small is Beautiful : John Ruskin
 C) The Life and Death of Mahatma Gandhi : Robert Payne
 D) The Conquest of Violence : Edwin Arnold
45. M.K. Gandhi was kept as a prisoner during Salt Satyagraha at:-
 A) Ahmadabad Jail B) Yervada Jail C) Agakhan Palace D) Sabarmati Jail
46. Gandhi started the publication of Harijan in:-
 A) 1919 B) 1925 C) 1933 D) 1940
47. Gandhi did not believe in one of the following:-
 A) Sarvodaya B) Satyagraha C) Non-violence D) Passive Resistance
48. Arrange the following publications in chronological order:-
 I Indian opinion
 II Harijan
 III Young India
 IV Hind Swaraj
 A) II, I, IV, III B) I, III, II, IV C) I, IV, III, II D) IV, II, I, III
49. I D C means:-
 A) International Development Council B) International Disarmament Committee
 C) International Disarmament Community D) International Development Commission
50. "War is neither an absolute evil nor an absolute accident", is the statement of:-
 A) Hegel B) Machiavelli C) M.K. Gandhi D) Nelson Mandela

x-x-x

Geology(1077)

1. Petrofabric analysis
 - A) Ignores the non-directional texture
 - B) Gives complete study of rock fabrics
 - C) Gives the megascopic structure only
 - D) Does not ignore the scalar fabric of rock
2. The lamprophyres characteristically exhibits
 - A) Allotriomorphic texture
 - B) Panidiomorphic texture
 - C) Automorphic texture
 - D) Hypidomorphic texture
3. Only one carbonatite [volcano](#) is known to have erupted in historical time, the only active [Ol Doinyo Lengai](#) volcano in
 - A) Brazil
 - B) Japan
 - C) Korea
 - D) Tanzania
4. Turbidity currents produce some
 - A) Trenches
 - B) Abyssal Hills
 - C) Submarine canyons
 - D) Hydrogenous sediments
5. Presence of phosphoritic beds in association with black shales is indicative of deposition of sediments in
 - A) Fresh water
 - B) Shallow sea with oxidising environment
 - C) Shallow sea with reducing environment
 - D) Deep sea
6. Extremely large ostracod of 25 millimetre size is
 - A) *Periocypris*
 - B) *Mongolocypis*
 - C) *Zonocypris*
 - D) *Gigantocypris*
7. A geothermometer is?
 - A) A thermometer designed to measure temperatures in deep-sea deposits or in bore holes deep below the surface of the earth
 - B) A device that measures current rock temperatures at the surface
 - C) A mineral assemblage that can reveal the minimum temperature attained during heating
 - D) Measuring the previous pressure and temperature history of a [metamorphic](#) or intrusive igneous rocks
8. Abutment is:
 - A) Upstream side of a dam
 - B) Downstream side of a dam
 - C) The sides of the valley on which the dam structure rests
 - D) Openings for discharge
9. Mid Oceanic ridges are characterized by
 - A) Shallow Earthquakes
 - B) Deep Earthquakes
 - C) Intermediate Earthquakes
 - D) Without any Earthquakes
10. A shallow level in Subduction zone, Terrane composed of broken and sheared rock fragments of different origins set in sheared matrix, these Terranes are known as
 - A) Ophiolites
 - B) Melange
 - C) Tectonites
 - D) Mylonites

11. In Karst cycle the beginning of diversion of surface drainage to subterranean routes with do lines as the characteristic landform is a feature of
- A) Youth stage
C) Old stage
- B) Mature stage
D) May form at any stage
12. “Landscape is a function of structure, process and stage”, the statement is given by
- A) James Hutton B) Penck C) Davis D) Plafair
13. Cranial capacity was highest in the (of brain)
- A) *Pondaugia*
C) Atlantic man
- B) *Dryopithecus*
D) Cro-magnon man
14. Joints which keep the same direction for long distances and seen through a considerable thickness of beds are called
- A) Master joint
C) Tensional joint
- B) Primary joint
D) Diagonal joint
15. The main difference between Pi and Beta diagram is
- A) In Pi diagrams, the poles of the perpendicular to the plane are projected while in Beta diagram the planes are projected
B) Pi diagram is plotted on equal area net, while Beta diagram is plotted on the stereographic net
C) In both the diagrams, the poles of the perpendicular to the plane are projected, thus there is no difference
D) Non plane and cylindrical
16. Caliper log measures
- A) Density of rock
C) Hydrogen atom densisty
- B) Electrical resistivity
D) Size of well bore
17. The unit of transmissivity is
- A) Darcy
C) Meter per day
- B) Square micrometer
D) Meter square per day
18. The most rapid drilling method for unconsolidated formation is
- A) Rotary percussion method
C) Reverse circulation rotary method
- B) Air rotary method
D) Jacob’s method
19. Which of the following rock types has highest compressive strength
- A) Granite B) Sandstone C) Limestone D) Marble

29. Average oil shales yield about
- A) 25 to 30 gal of petroleum per ton of shale
 - B) 10 to 20 gal of petroleum per ton of shale
 - C) 30 to 50 gal of petroleum per ton of shale
 - D) 50 to 70 gal of petroleum per ton of shale
30. What thickness of cover rock is generally thought necessary to generate petroleum and natural gas from organic material?
- A) 1000 m
 - B) 1500 m
 - C) 3000 m
 - D) 2000 m
31. At which of the following boundaries, Lithosphere plates slide past each other
- A) Transform
 - B) Convergent
 - C) Divergent
 - D) Island arc
32. Stress minerals are characterised with
- A) Flaky, platy and elongated shapes
 - B) Angular, regular and polyhedral outlines
 - C) Perfectly rounded and granular minerals
 - D) Sub circular, less rounded outlines
33. Velocity of longitudinal seismic waves in sedimentary rocks is in the range of
- A) 2-3 km/sec
 - B) 4.5-7 km/sec
 - C) 3-4 km/sec
 - D) 6.5-6.7 km/sec
34. In a place having a very narrow gorge with very good construction material available in abundance and there being shales at the base and hard and strong dolomites being along the abutments the engineer would normally go for a
- A) Gravity dam
 - B) Arch dam
 - C) Earthen dam
 - D) Buttress dam
35. Differential movement along closely spaced fractures results in
- A) Flexure folds
 - B) Shear folds
 - C) Flow folds
 - D) Glitbrett folds
36. The metamorphic facies which is characteristic of low geothermal gradients and found associated with geosynclines is referred as
- A) Blueschist facies
 - B) Glaucoophane schist facies
 - C) Eclogite facies
 - D) Sanidinite facies
37. The Radiolaria, also called Radiozoa, are [protozoa](#) of diameter ranging from
- A) 0.1-0.2 mm
 - B) 0.3-0.5 mm
 - C) 0.5-0.8 mm
 - D) 0.8-1.0 mm

38. Groundwater in hard rock terrenes can be tapped by
- A) Digging tube wells
 - B) Building tanks
 - C) Digging open wells of large diameters
 - D) Subsequent stream
39. The best known section for the Permian-Triassic boundary in India is
- A) Kashmir
 - B) Garhwal
 - C) Salt range
 - D) Assam
40. Biogenic oozes, red clays and poly-metallic nodules are the typical sediments found in
- A) Littoral zone
 - B) Neritic zone
 - C) Bathyal zone
 - D) Abyssal zone
41. The time of rapid evolutionary change of a new taxa or the adaptive radiation is described as
- A) Tachytelic evolution
 - B) Bradytelic evolution
 - C) Orthogenesis
 - D) Paragenesis
42. Ignimbrites are
- A) Volcanic bombs
 - B) Welded tuffs
 - C) Volcanic glasses
 - D) Volcanic breccias
43. A coarse grained plutonic igneous rock consisting of more than 90% plagioclase feldspar, the remainder being made up of other gabbroic minerals
- A) Lamprophyres
 - B) Kimberlites
 - C) Charnockites
 - D) Anorthosite
44. Magnetization formed by cooling below the Curie point is called
- A) Detrital remanent magnetization
 - B) Chemical remanent magnetization
 - C) Natural remanent magnetization
 - D) Thermal remanent magnetization
45. When oceanographic and climatic changes occur; some isotopes can become more or less abundant with respect to others, due to
- A) Oceanic circulation
 - B) not controlled by ice volume
 - C) Fractionation, or separation of isotopes by their differences in atomic weight
 - D) Non fractionation, or partition of isotopes by their addition in atomic weight
46. The difference between the observed and the predicted gravity values after applying all the corrections is described as
- A) Free-air anomaly
 - B) Free-air correction
 - C) Bouguer anomaly
 - D) Bouguer correction

47. Which of the following has the least electrical resistivity?

- A) Diamond
- B) Sulphur
- C) Clay
- D) Anthracite

48. Peat and lignite may contain pollen grains. These are obtained by dissolving in

- A) Wultz Solution
- B) Schulze solution
- C) Clerici's solution
- D) CCL4

49. Lamprophyres generally occur as:

- A) Batholiths
- B) Dykes and sills
- C) Plutons
- D) Laccolith

50. Fusulinida is characteristic foraminifers of

- A) Lower Silurian to Upper Permian
- B) Jurassic
- C) Lower- Middle Eocene
- D) Lower to Upper Pliocene

x-x-x

Sikh Studies(Ph.D.)

1. Identify which saying is incorrect according to Sikhism:
A) Degh Tegh Fateh
B) Fear and Frighten
C) Sarbat Da Bhalla
D) Chardi Kala
2. Name the Seventh Guru of Sikh Guru Tradition
A) Guru Har Rai
B) Guru Harkrishan
C) Guru Tegh Bahadur
D) Guru Har Gobind
3. Hymns are not included in Guru Granth Sahib of Bhagat :
A) Kabir
B) Jaidev
C) Tulsidas
D) Pipa
4. Guru Tegh Bahadur's Martyrdom took place in the reign of
A) Babur
B) Aurangzeb
C) Jahangir
D) Bahadur Shah
5. Whose Guru's Bani is in maximum given in Guru Granth Sahib?
A) Guru Nanak Dev
B) Guru Arjan Dev
C) Guru Amardas
D) Bhai Gurdas
6. In which year Guru Gobind Singh has formed the Khalsa Panth
A) 1704
B) 1706
C) 1699
D) 1708
7. Sikhism believes in:
A) Gender inequality
B) Caste difference
C) Idol worship
D) Welfare to all
8. Which is not right according to Sikh Gurus :
A) Kirat Karna, Vand Chhakna, Nam Japna
B) Intoxications
C) Daswandh
D) Honour to women
9. Guru Amardas's 'Anand Sahib' is written in Rag
A) Suhi
B) Sorth
C) Ramkali
D) Majh
10. Which Guru had included the hymns of Guru Tegh Bahadur in Guru Granth Sahib
A) Guru Arjan Dev
B) Guru Harboind
C) Guru Har Rai
D) Guru Gobind Singh
11. Guru Nanak's 'Baramaha' is written in :
A) Majh Rag
B) Aasa Rag
C) Tukhari Rag
D) Gauri Rag
12. 'Aasa Di Var' Bani is directed to recite on the dhuni of :
A) Hasne Maheme di var
B) Tunde Asraje di Var
C) Malak Murida Chanderhare di Var
D) Lala Behleema di Var
13. 'Ranghreta- Guru Ka Beta' was given the name by Guru Gobind Singh to whom :
A) Bhai Lakhi Shah
B) Bhai Jaita
C) Bhai Sangat
D) Bhai Sant
14. Tick the right option :

- A) Dharam Adhyan Patarika (Journal) is published by Punjabi University Patiala
 B) Panjab Journal of Sikh Studies is published by Panjab University Chandigarh
 C) Abstract of Sikh Studies (Journal) is published by Delhi University Delhi
 D) Studies in Sikhism and Comparative Religion (Journal) is published by Guru Nanak Dev University Amritsar
- 15.** Which is incorrect as regards to japuji sahib :
- A) Dharam Khand
 B) Gyan Khand
 C) Bhakti Khand
 D) Sach Khand
- 16.** Which is the incorrect
- A) Guru Nanak Dev's Bani is Sidh Ghost
 B) Guru Amardas Bani is Ramkali Anand
 C) Guru Ramdas Bani is Sukhmani Sahib
 D) Guru Arjan Dev Bani is Baramaha Majh
- 17.** Sikhism believes in
- A) One God
 B) Co-existence
 C) 'Kuri Maar' and 'Nari Maar'
 D) Social Justice
- 18.** Identify the incorrect answer :
- A) Model of 'Sachiar' is given in Japuji
 B) Model of Param Sukh is given in 'Sukhmani'
 C) Model of Param Anand is given in Anand Sahib
 D) Model of Sachi Taksal is given in Aasa Di Var
- 19.** Rahit Namas deals with :
- A) Sikh Aesthetics
 B) Sikh Ethics
 C) Sikh Philosophy
 D) Sikh History
- 20.** What was the earlier name of Institution of Gurdwara :
- A) Mandir
 B) Math
 C) Dharamsala
 D) Pathshala
- 21.** Zaffarnama by Guru Gobind Singh was addressed to :
- A) Emperor Akbar
 B) Emperor Farukhsiar
 C) Banda Bahadur
 D) Badshah Aurangzab
- 22.** 'Aarti' is written in Rag :
- A) Ramkali
 B) Soohi
 C) Dhanasari
 D) Gujri
- 23.** Which University has published the Guru Granth Vishav Kosh
- A) Guru Nanak Dev University, Amritsar
 B) Panjab University, Chandigarh
 C) Punjabi University, Patiala
 D) Delhi University, Delhi
- 24.** The author of Gurshabad Ratnakar Mahan Kosh is :
- A) Bhai Jodh Singh
 B) Bhai Randhir Singh
 C) Bhai Vir Singh
 D) Bhai Kahan Singh Nabha

- 25.** Find Out the correct statement:
 A) Sikhism is based upon the Sant Tradition
 B) Sikhism is a synthesis of Hinduism and Islam
 C) Sikhism is a revealed religion
 D) Sikhism matches with Sufism
- 26.** Sikh Faith believes in:
 A) Multi gods B) Rituals C) Co-existence D) Intoxications
- 27.** Who had first researched on the 'Ikadsi Mahatam' :
 A) Dr. Rattan Singh Jaggi B) Dr. Tarlochan Singh Bedi
 C) Dr. Piar Singh D) Dr. Mohan Singh Diwana
- 28.** Primary source of Chandi Di Var is
 A) Garurh Paran B) Sam Ved
 C) Markande Puran D) Dasam Granth
- 29.** Which Bani is Rag Mukat Bani
 A) Japuji B) Anand C) Sukhmani D) Aasa Di Var
- 30.** Which is given at the end of Guru Granth Sahib
 A) Salok Vaaran te Vadhik B) Rag Mala
 C) Rehras D) Kirtan Sohila
- 31.** Personal Guruship came to an end in Sikhism with whom :
 A) Guru Arjan B) Guru Tegh Bahadur
 C) Guru Gobind Singh D) Baba Banda Singh Bahadur
- 32.** Mission of Guru Gobind Singh's Khalsa Panth is:
 A) To fight against the evil forces B) To protect the Hindus Religion
 C) To curb the spread of Islam Religion D) To drag the wealth of rich people
- 33.** Which source of Sikh History is not correct:
 A) Vaaran Bhai Gurdas B) Guru Granth Sahib
 C) Aanad Parkas D) Panth Parkash
- 34.** Which Answer is incorrect :
 A) 'An Introduction to Sri Guru Granth Sahib' book is written by Dr. Sahib Singh
 B) 'Ethics of the Sikhs' book is written by Dr. Avtar Singh
 C) 'Guru Nanak and the Sikh Religion' book is written by W.H. Mcleod
 D) 'Hum Hindu Nahin Hain' book is written by Bahi Kanh Singh Nabha
- 35.** Who has written 'Sri Gurpartap Suraj Granth'
 A) Rattan Singh Bhangoo B) Giani Gian Singh
 C) Bhai Santokh Singh D) Bhai Sukha Singh

36. The following Sikh Piaras were from (give the right option) :
- A) Bhai Dya Singh was from Lahore
 - B) Bhai Himat Singh was from Hastanapur Delhi
 - C) Bhai Mohkam Singh was from Jagannath Puri
 - D) Bhai Sahib Singh was from Dwaraka Puri
37. Which Guru has used the word 'Hindustan' in his hymns (first time)
- A) Guru Gobind Singh
 - B) Guru Har Gobind Singh
 - C) Guru Nanak Dev
 - D) Guru Har Rai
38. Which is the correct answer:
- A) 'Kita Pasao, Aako Kava' said by Guru Nanak Dev
 - B) 'Bhia Kaho Ko Dait Nahi' said by Guru Gobind Singh
 - C) 'Soora sau Pechaniye jo lade Deen Ke Hait' said by Guru Tegh Bahadur
 - D) 'Jau Tau Prem Khelan Ka Chao' said by Kabir
39. Which emperor met Guru Angad Dev in Khadoor Sahib
- A) Akbar
 - B) Babur
 - C) Hammau
 - D) Jahangir
40. Which option is not right :
- A) Guru Amardas has established 22 Preaching centers
 - B) Guru Har Gobind Ji introduced two swords – Miri Piri
 - C) Guru Gobind Singh was the creator of Khalsa Panth'
 - D) Guru Arjan Dev Ji gave the honour of 'Supreme Guru' to Adi Granth
41. Which is the right answer
- A) Bhagat Namdev was from Bengal
 - B) Bhagat Jaidev was from Maharashtra
 - C) Bhagat Ravidas from Luknow
 - D) Bhagat Dhanna was from Rajasthan
42. Who was the founder of Namdhari (Kuka) Movement
- A) Baba Jagjit Singh
 - B) Baba Balak Singh
 - C) Baba Ram Singh
 - D) Baba Ratta
43. Which Bhatt's name is not given correct in the names of mentioned below :
- A) Bhatt Kalamsar
 - B) Bhatt Kirat
 - C) Bhatt Nalay
 - D) Bhatt Bhikha
44. What was the name of father of Guru Tegh Bahadur Ji.
- A) Guru Har Gobind
 - B) Guru Har Rai
 - C) Baba Gurdita
 - D) Attal Rai
45. Who was Dhir Mal
- A) Son of Guru Har Rai
 - B) Brother of Guru Hargobind
 - C) Father of Guru Harkrishan
 - D) Brother of Guru Har Rai

46. Which name is given to a Self-oriented person in Sikhism out of the following?
A) Manmukh B) Malechha C) Masand D) Mastana
47. Find out the correct answer :
A) Sahib Singh - Sachi Sakhi
B) Puran Singh - The Spirit Born People
C) Kapur Singh - Gurbani Viyakaran
D) Bhai Jodh Singh - Gurmat Martand
48. Identify the chronic disease according to Sikhism :
A) Maya B) Houmai C) Masands D) Malechha
49. Guru Tegh Bahadur's martyrdom took place :
A) 1656 B) 1669 C) 1675 D) 1676
50. Tick the right option regarding : Who is the Chief Editor of Sikh Dharam Vishav Kosh
A) Dr. Jodh Singh B) Dr. Rattan Singh Jaggi
C) Dr. Balkar Singh D) Dr. Gurnaib Singh

x-x-x

History(1077)

1. First long inscription written in pure Sanskrit is
 - A) Junagarh Rock Inscription
 - B) Gurjara-Pratihara Inscription
 - C) Lumbini Pillar Inscription
 - D) None of these
2. Megasthenese visited the court of
 - A) Samudragupta
 - B) Harshvardhana
 - C) Chandragupta Maurya as ambassador of Seleucus
 - D) Chandragupta Maurya as ambassador of Alexander
3. Shikarpur is a Harappan site in
 - A) Rajasthan
 - B) Gujarat
 - C) Punjab
 - D) Haryana
4. Which of the following was added as a third Pitaka to existing Buddhist literature?
 - A) Suta Pitaka
 - B) Vinaya Pitaka
 - C) Abhidhamma Pitaka
 - D) None of these
5. Who is the author of the Jaina Kalpasutra, an invaluable source for early history of Jainism?
 - A) Bhadrabahu
 - B) Sambhuta Vijaya
 - C) Mahavir
 - D) Sthulabahu
6. Who was Einstein of India?
 - A) Nagasena
 - B) Nagarjuna
 - C) Ashvagosha
 - D) Buddha Gosha
7. Agraharas were
 - A) Land grants
 - B) Royal Titles
 - C) Military ranks
 - D) Gold plates
8. Dana-Stutis literally meant 'in praise of gifts' were composed by
 - A) Kings
 - B) Merchants
 - C) Queens
 - D) Priests
9. Manram for village administration in Sangam Age was
 - A) A guild
 - B) A council of tax collectors
 - C) A council of elders
 - D) A local assembly
10. Hiranya during Gupta period was
 - A) A Military General
 - B) A tax
 - C) A political ideology
 - D) A religious body
11. The capital of Rashtrakutas was
 - A) Malkhed
 - B) Kalyani
 - C) Vengi
 - D) Badami

12. Ghatikas were

- A) Jain educational centres
- B) Buddhist educational centres
- C) Village assemblies
- D) Brahmanical institutions for higher studies

13. Diwan-i-Arz was

- A) Ministry of Defence
- B) Department of Correspondence
- C) Ecclesiastical Department
- D) Judicial Department

14. Tark-e-Duniya, a Sufi concept refers to

- A) The tolerant world
- B) Renunciation of world
- C) The enlightened world
- D) None of these

15. The Bhakti Saints of Saguna School were confirmists. Which of the following does not belong to this School?

- A) Mira Bai
- B) Kabir
- C) Surdasa
- D) Tulsidasa

16. Octagonal shaped tombs are associated with

- A) Khaljis
- B) Tughlaqs
- C) Saiyyads
- D) Lodis

17. Tabqat-i-Nasiri was written by

- A) Minhaj-us-Siraj
- B) Firuz Shah Tughlaq
- C) Balban
- D) Ibn Batuta

18. Paymaster of provincial armies under Mughals was

- A) Faujdar
- B) Diwan
- C) Kotwal
- D) Bakshi

19. Which of the following Mughal painters was at Jahangir's court?

- A) Abdul Hasan
- B) Ustad Mansur
- C) Aga Reza
- D) Muhammad Nadir

20. What were Saranjams?

- A) Salaries
- B) Hereditary rights in land
- C) Revenue grants
- D) Tax-free lands

21. The city of Dinpanah was built by

- A) Babur
- B) Humayun
- C) Sher Shah
- D) Akbar

22. What was Majlis-i-Am during the Sultanate period?
- A) Officers in-charge of accounts
 - B) Custodians of peace
 - C) Council of teachers
 - D) Council of trusted officers consulted by Sultan on important matters
23. Under which land revenue system, produce was divided between peasants and the state in fixed proportion
- A) Nasaq
 - B) Kankut
 - C) Batai
 - D) None of these
24. Who built Hazara Rama temple?
- A) Harihara I
 - B) Harihara II
 - C) Devaraya I
 - D) Devaraya II
25. The perennial canals have
- A) Water only in rainy seasons
 - B) No water at all
 - C) Water through all seasons
 - D) Water for two months
26. Who does not consider Guru Nanak as a revolutionary?
- A) Bhai Kahan Singh
 - B) Ganda Singh
 - C) Teja Singh
 - D) I. B. Banerjee
27. Who was the foreign minister of Maharaja Ranjit Singh?
- A) Fakir Aziz-ud-din
 - B) Hari Singh Nalwa
 - C) Dina Nath
 - D) Bhawani Das
28. The foundation stone of Harimandir Sahib was laid by
- A) Bhai Buddha
 - B) Mian Mir
 - C) Bhai Lehna
 - D) Bhai Jetha
29. The last battle between Banda Singh Bahadur and the Mughals was
- A) Battle of Rahon
 - B) Battle of Lohgarh
 - C) Battle of Gurdas Nangal
 - D) Battle of Bahrampur
30. The first Director of Department of Public Instruction in Punjab in 1856 was
- A) T. W. Arnold
 - B) William Hunter
 - C) William Smith
 - D) T. H. Thornton

42. Who described Tilak as “the Father of Indian Unrest”?
- A) Lord Chelmsford
B) Annie Besant
C) Valentine Chirol
D) M. K. Gandhi
43. Mixed Economy refers to the co-existence of
- A) Rich and poor people
B) Agrarian economy and industrial economy
C) Villages and towns
D) Public sector and private sector
44. The Chitagong Armoury Raid was led by
- A) Anand Prasad Gupta
B) Surya Sen
C) Subodh Roy
D) Debi Prasad Gupta
45. Khan Bahadur Khan led the revolt of 1857 at
- A) Jhansi
B) Indore
C) Bareilly
D) Satara
46. Mahatma Gandhi presided over Annual Session of Congress at
- A) Gauhati
B) Belgaum
C) Kanpur
D) Amritsar
47. Who assassinated Curzon Wyllye?
- A) Bhagal Singh
B) S. C. Bose
C) Madan Lal Dhingra
D) Rajguru
48. Fort St. George, the British Fort in India was built at
- A) Calcutta
B) Bombay
C) Poona
D) Madras
49. The Committee which recommended inclusion of Fundamental Duties in our Constitution was
- A) Barua Committee
B) Ramaswamy Committee
C) Swaran Singh Committee
D) Sikri Committee
50. Who makes appointments of All India Services?
- A) Parliament
B) Council of Ministers
C) U. P. S. C.
D) President of India

x-x-x

1. The author of the Rasamanjari is
A) Bhanudatta B) Jayadeva C) Mulla Daud D) Bilhan
2. A chronogram is a method to
A) Measure space B) Express a date or epoch
C) Eulogise a ruler D) Calculate distance
3. Takri inscriptions are associated with
A) Pahari miniature paintings B) Deccani miniature paintings
C) Mughal miniature paintings D) Sultanate miniature paintings
4. Recto is the
A) Margin of a folio B) Front side of a folio
C) Back of a folio D) Main support of a folio
5. Orpiment, used as yellow colour in Indian miniature painting, is a
A) Mercuric sulfide mineral B) Copper compound
C) Iron oxide D) Arsenic sulfide mineral
6. The time period of the Angkor Vat is
A) 9th century AD B) 10th century AD
C) 12th century AD D) 14th century AD
7. Which one of the following is a brick structure?
A) Temple of Lakshmana at Sirpur B) Shiva temple at Bhamara
C) Huchchimalligudi temple D) Malegitti temple
8. The Government School of Art, Calcutta was established in
A) 1850 B) 1854 C) 1857 D) 1870
9. The *Bageshwari Shipla Prabandhavali* is a compilation of essays by
A) Rabindranath Tagore B) Samarendranath Gupta
C) Abanindranath Tagore D) Asit Kumar Haldar
10. The correct chronological order for the following is
A) Kalan Masjid, Alai Drwaza, Moth-ki-Masjid, Shish Gumbad
B) Kalan Masjid, Alai Darwaza, Shish Gumbad, Moth-ki-Masjid
C) Alai Darwaza, Shish Gumbad, Alai Darwaza, Moth-ki-Masjid
D) Alai Darwaza, Kalan-Masjid, Shish Gumbad, Moth-ki-Masjid
11. Firoz Shah Tughlaq founded which one of the following?
A) Jaunpur B) Jahanpannah C) Tughlaqabad D) Fatehpur Sikri
12. Which one of the following is an example of the Gothic style of architecture?
A) St. Mark's, Venice B) Hagia Sophia
C) Amiens Cathedral D) St. Peter's, Rome
13. The South Doors of the Florence Baptistery are by
A) Lorenzo Ghiberti B) Donatello
C) Andrea da Pisano D) Giovanni Pisano

14. Der Blaue Reiter started in
 A) Dresden B) Cologne C) Berlin D) Munich
15. At present the number of edifices and monuments in the Capitol Complex, Chandigarh is
 A) 4 B) 5 C) 6 D) 7
16. An *Ayagapatta* is a
 A) Pedestal B) Stele C) Votive slab D) Keystone
17. The *Padshahnama* is an account of the reign of
 A) Jahangir B) Shahjahan C) Aurangzeb D) Bahadur Shah II
18. The correct match in the following is
 A) A. K. Coomaraswamy – A Survey of painting in the Deccan
 B) Rabindranath Tagore – What is Art?
 C) Stella Kramrisch – An Approach to Indian Art
 D) Niharranjan Ray – Christian and Oriental Philosophy of Art
19. The ‘Rampurva Bull Capital’ is displayed in the
 A) Sarnath Museum B) Indian Museum, Kolkata
 C) National Museum, Delhi D) Rashtrapati Bhawan, Delhi
20. The Indian Printmakers Guild was established in the year
 A) 1988 B) 1990 C) 1993 D) 1997
21. The correct match in the following is
 A) Marcel Duchamp – Recumbent Figure
 B) Henry Moore – Human Concretion
 C) Jean Arp – Fountain
 D) Constantin Brancusi – The Newborn
22. The correct chronological order among the following is
 A) Sittannavasal, Mattancheri, Bagh, Tanjore
 B) Bagh, Sittannavasal, Tanjore, Mattancheri
 C) Sittannavasal, Bagh, Tanjore, Mattancheri
 D) Tanjore, Bagh, Sittannavasal, Mattancheri
23. The author of *Muntakhab’ uttawarikh* is
 A) Abu’l Fazl B) Badauni C) Qutban D) Mir Ala al-Dawla
24. The Kushana period sculpture among the following is
 A) Yaksha Manibhadra from Pawaya
 B) Yakshi from Didarganj
 C) Bodhisattva of Friar Bala from Sarnath
 D) Buddha from Sultanganj
25. Anjali mudra is the gesture of
 A) Discussion B) Preaching C) Devotion D) Blessing
26. The author of *Concerning the Spiritual in Art* is
 A) Franz Marc B) Paul Klee C) Piet Mondrian D) Vasily Kandinsky

27. De Stijl was founded in
 A) Amsterdam B) Paris C) New York D) Moscow
28. The Dada movement began in the year
 A) 1914 B) 1916 C) 1919 D) 1924
29. The correct chronological order among the following is
 A) Ionic, Doric, Corinthian B) Doric, Corinthian, Ionic
 C) Doric, Ionic, Corinthian D) Corinthian, Doric, Ionic
30. Who among the following is a Northern European artist?
 A) Simone Martini B) Cimabue C) Duccio D) Robert Campin
31. The thinker and theoretician from ancient India is
 A) Visvanatha B) Rupa Goswamin C) Dhvanikara D) Jagannatha
32. TLR and SLR are types of
 A) Printer B) Lens C) Film D) Camera
33. The correct matches among the following are
 1. Tyeb Mehta i. Winged Pilgrims a Chronicle from Asia
 2. Sheba Chhachhi ii. Sita/Medea
 3. Krishen Khanna iii. Mahisha series
 4. Nalini Malani iv. Rear View series
 A) 1-ii, 2-i, 3-iv, 4-iii B) 1-iii, 2-i, 3-iv, 4-ii
 C) 1-iv, 2-ii, 3-i, 4-iii D) 1-iii, 2-iv, 3-ii, 4-i
34. Bevelling, Burr and Feathering are terms associated with
 A) Printmaking B) Photography C) Painting D) Sculpture
35. The Rajarani temple is located in
 A) Khajuraho B) Mt. Abu C) Gwalior D) Bhubaneswar
36. The correct chronological order among the following is
 A) Chola, Pandya, Pallava, Vijayanagar
 B) Pallava, Chola, Pandya, Vijayanagar
 C) Pandya, Pallava, Vijayanagar, Chola
 D) Pandya, Pallava, Chola, vijayanagar
37. *New Documents of Indian Painting* is by
 A) BN Goswamy and Eberhard Fischer
 B) William Dalrymple and Yuthika Sharma
 C) K Khandalvala and M Chandra
 D) D Barrett and B Gray
38. The British artist among the following is
 A) Alexander Calder B) Max Ernst
 C) Barbara Hepworth D) Joan Miro

39. The architect of the Gandhi Bhawan in Chandigarh is
 A) Pierre Jeanneret B) Le Corbusier C) Maxwell Fry D) Jane Drew
40. The Planographic process among the following is
 A) Mezzotint B) Drypoint C) Woodcut D) Lithography
41. Synthetic Cubism began in
 A) 1909 B) 1910 C) 1912 D) 1914
42. The art historian among the following is
 A) Jaya Appasamy B) Raghu Rai
 C) Devyani Krishna D) Dayanita Singh
43. The Company School painter among the following is
 A) Nidha Mal B) Nihal Chand C) Miskin D) Jairam Das
44. Who among the following studied at the Mayo School of Art, Lahore?
 A) Satish Gujral B) Krishen Khanna C) Prem Singh D) B C Sanyal
45. Numismatics is the study of
 A) Coins B) Ancient inscriptions
 C) Paintings D) Sculptures
46. Collography is a technique of
 A) Sculpture B) Painting C) Printmaking D) Photography
47. The author of *The Story of Art* is
 A) E. H. Gombrich B) C. Bell C) H. Read D) R. Fry
48. The architect of St. Peter's, Rome is
 A) Alberti B) Michelangelo C) Vasari D) Sansovino
49. The National Museum, New Delhi was inaugurated in the Rashtrapati Bhawan in the year
 A) 1949 B) 1954 C) 1957 D) 1965
50. The correct matches among the following are
- | | |
|------------------------|------------------|
| 1. Virupaksha temple | i. Chola |
| 2. Kailash temple | ii. Pallava |
| 3. Shore temple | iii. Rashtrakuta |
| 4. Brihadeswara temple | iv. Chalukyan |
- A) 1-ii, 2-iii, 3-i, 4-iv B) 1-iv, 2-iii, 3-ii, 4-i
 C) 1-iv, 2-ii, 3-i, 4-iii D) 1-iii, 2-iv, 3-ii, 4-i

x-x-x

1. Chemical compounds in foods which perform one or more specific function in the body are called
A) Protein B) Nutrients C) Antioxidants D) Fiber
2. An insoluble ion exchange compound used in most heavy duty detergents is
A) Sodium silicate B) Ethylene oxide
C) Zeolite D) Sodium carbonate
3. Inability to differentiate between the size and volume by the preschool children is termed as
A) Animism B) Conservation C) Differentiation D) Confusion
4. In Kashmiri shawls if the embroidery is the same on both sides, the shawl is known as
A) Khatraaz B) Dorukha C) Ekrukha D) Chaurukha
5. Which of the following is not related to family budget planning
A) Estimate income B) Estimate expenditure
C) Increase income D) Balance income and expenditure
6. Another name of Likert scale is
A) Event sampling B) Measurement scale
C) Summated rating scale D) Ranking
7. Totally incomplete protein are
A) Egg and fish B) Trypsin and haemagglutinin
C) Zein and gelatine D) Fruits and vegetables
8. If a researcher wants to report with 99% accuracy he would set the level of significance at
A) .05 B) .95 C) .01 D) .10
9. Pro biotic foods contain
A) Live friendly bacteria B) Multiple microorganisms
C) Active antibiotics D) Fresh curd
10. Which of these is not a method to resolve a conflict
A) Agreeing to negotiate B) Seeking legal recourse
C) Seeking professional counselling D) Indulging in domestic violence
11. Effective way of teaching to pre-school children
A) Guided teaching B) Play way teaching
C) Black Board teaching D) Digital teaching
12. Substances which retard / prevent the growth of microorganisms in food are
A) Food additives B) Preservatives C) Antibiotics D) Antioxidants

13. The difference between the cost and selling price of goods is
A) Stock to sales ratio B) Mark up C) Mark down D) Inventory
14. Which of the following is a natural isotonic beverage with a similar electrolyte balance as in blood
A) Water B) Kokamsherbet C) Lemon water D) Coconut water
15. TAT is a
A) Projective psychological test B) Method of introspection
C) Projective differentiation test D) Method of lie detector
16. Reference man is
A) Adult man between 29-39 years of age, 165 cm height and 60 kg weight
B) Adult man between 20-39 years of age, 163cm height and 60kg weight
C) Adult man between 29-39 years of age, 170cm height and 60 kg weight
D) Adult man between 18-29 years of age, 173 cm height and 60 kg weight.
17. WASH practices refer to
A) Water, air, sanitation, hygiene B) Water, air, safety, health
C) Water, air, sanitation, health D) Water, sanitation and hygiene
18. "HACCP" stands for
A) Heavy action critical control point B) Hazard analysis critical control point
C) High application critical control point D) Health analysis critical control point
19. Diuretics are drugs used for
A) Control of blood sugar B) Control Uris acid levels
C) Stimulate insulin secretion D) Stimulate urine flow
20. The number of units of weight in a unit of length is known as
A) Count B) Twist C) Denier D) Filament
21. FSSAI was created for
A) Laying down and maintaining standards for food products
B) Determination of weights and measures
C) Dealing with ethical issues of GM foods
D) Safety of farm produce.
22. Which is not associated with the Phallic stage of psychoanalytic theory
A) Biting B) Oedipus complex
C) Electra Complex D) Castration anxiety
23. The approach of non formal education should be
A) Literacy oriented B) Learner oriented
C) Timetable oriented D) Examination oriented

- 35.** The principle of extension education involves
- A) Principle of participation and adaptability
 - B) Principle of controlling
 - C) Principle of cultural similarity
 - D) Principle of organising
- 36.** Which knit has excellent crosswise and lengthwise stretch
- A) Rib
 - B) Purl
 - C) Tuck
 - D) Float
- 37.** Home Science Education through its extension programs specifically
- A) Trains rural women to adopt wage employment
 - B) Gives job guarantee to women
 - C) Provides finance for starting new enterprises
 - D) Diversifies non farm activities
- 38.** Which aspect of research design may or may not be accepted on the completion of the research
- A) The objectives
 - B) The theoretical framework
 - C) The hypothesis
 - D) The conclusions
- 39.** Control group in research design is
- A) Group of units exposed to existing conditions
 - B) Group of units exposed to special conditions
 - C) Group which has only extraneous variables
 - D) Group of units exposed to pretested conditions
- 40.** A researcher has to conduct a survey on a large number of industrial units in India, which sampling technique will he adopt
- A) Simple random sampling
 - B) Convenience sampling
 - C) Cluster sampling
 - D) Snow ball sampling
- 41.** Interviewing all members of a given population is called
- A) Gallup poll
 - B) Census
 - C) Nielsen audit
 - D) Univariate sample
- 42.** The abstract of a report
- A) Is written before the report
 - B) Is an introduction of the report
 - C) Is the conclusion of the report
 - D) Is a concise summary of the whole report
- 43.** Which of the following is an incorrect statement related to work simplification
- A) Develop easy and simplest way to do the task
 - B) Encourage smooth and rhythmic motion
 - C) Lowers time and energy expenditure
 - D) Lowers productivity

- 44.** Antioxidants are substances which
- A) Retard/prevent free radical damage in the body
 - B) Prevent oxidation and rusting of iron
 - C) Lower immunity in the body
 - D) Prevent spoilage of food
- 45.** Resting energy expenditure is synonymous to
- A) SDA
 - B) Thermogenesis
 - C) BMR
 - D) Exercise
- 46.** For effective communication
- A) The receiver must agree with you
 - B) The receiver must accept the information
 - C) The information must be understood by the receiver
 - D) The receiver must give feedback
- 47.** The ability to retain a given size and shape through use and care is
- A) Dimensional stability
 - B) Abrasion resistance
 - C) Cohesive stability
 - D) Drape stability
- 48.** When two different polymers are combined and extruded the process is known as
- A) Aerodynamic spinning
 - B) Mechanical spinning
 - C) Biconstituent spinning
 - D) Self theist spinning
- 49.** If a researcher is studying the cholesterol levels in the sample, the cholesterol levels are
- A) Continuous variable
 - B) Ordinal variable
 - C) Nominal variable
 - D) Concrete variable
- 50.** Choose the incorrect option
- A) Low motivation can cause fatigue
 - B) Low motivation leads to release of less energy
 - C) Unfinished task leads to physiological fatigue
 - D) Disliking a job leads to boredom fatigue

x-x-x

Human Rights and Duties(M.Phil.) (1077)

1. Identify the judge who is associated with the origin of Public Interest Litigation.

- A) Justice Ranganath Mishra B) Justice Venkatachalaiah
C) Justice P.N. Bhagwati D) Justice H.H. Baig

2. Who of the following was not instrumental in the drafting of the UDHR?

- A) John Peters Humphrey B) Eleanor Roosevelt
C) Franklin Delano Roosevelt D) Charles Malik

3. Name the book written by John Locke

- A) Social Contract B) Emile
C) Two Treatise on Civil Government D) Leviathan

4. The phrase 'Human Rights' was first used in

- A) Covenant of the League of Nations
B) Charter of UN
C) French Declaration of the Rights of Man
D) American Declaration of Independence

5. What is the correct sequence of the following events

- (i) French Revolution
(ii) American War of Independence
(iii) Magna Carta
(iv) Glorious Revolution

- A) iii, iv, ii, i B) iv, iii, ii, i C) iv, iii, i, ii D) iii, iv, i, ii

6. Match List I and List II and select the correct answer from the codes given below

List I

(Commissions/Committees)

- a) K.Santhanam
b) Shah Commission
c) Ashok Mehta Committee
d) Bhure Lal Committee

- A) a (ii), b (i), c (iii), d (iv)
C) a (iii), b (ii), c (iv), d (i)

List II

(Subject)

- (i)Godhra Train Carnage
(ii)Corruption
(iii) Panchayati Raj
(iv) Environmental Pollution

- B) a (i), b (ii), c (iii), d (iv)
D) a (ii), b (iv), c (iii), d (i)

7. Which one of the following Convention deals with regulating the trade of Hazardous Waste?

- A) Basel Convention B) Geneva Convention

16. Arrange the following events chronologically:

- a) Declaration of St. Petersburg
- b) First Hague Peace Conference
- c) Brussels Declaration
- d) Oxford Manual

A) a, c,b,d B) c,b,d,a C) c,d,a,b D) b,a,d,c

17. The oldest Women's Organization formed in 1927 is the

- A) Working Women's Forum
- B) Self-employed women's Association
- C) All India Women's Conference
- D) National Federation of Indian Women

18. "It is better to light a candle than curse the darkness" This sentence is associated with

- A) UN high Commissioner on Human Rights
- B) People's Union for Civil Liberties
- C) Amnesty international
- D) International Red Cross Society

19. Who Propounded the 'Rule of Law'?

- A) Duguit B) Machiavelli
- C) A.V. Dicey D) Friedrich Engles

20. What is the time limit to file complaint before the National Commission on Human Rights after the violation take place?

- A) Three months B) Six months C) One Year D) No limitation

21. According to Vienna Declaration, Dignity is:

- A) Common basis of all human beings
- B) Primarily a base for civil and political rights
- C) A characteristic for identity
- D) Not an essential base of human rights.

22. Which one of the following theories is known as 'Voices from periphery'?

- A) Modernization B) Class-struggle
- C) Dependency D) Imperialism

23. New Dependency emphasizes on:

- A) Surplus extraction as the major cause of underdevelopment
- B) Monopoly of trade complemented by a monopoly of land, mines and manpower in developing countries
- C) Domination of capital by hegemonic centers
- D) Investment by multinational corporations

24. The most essential principle of liberalism is:
 A) Equality B) Social justice C) Freedom D) Democracy
25. Patriarchal capital accumulation vision needs to be challenged by
 A) Strengthening of Human Rights Discourse
 B) Recovery of the feminine principle
 C) Expanding development
 D) Improving economic status of women
26. Who among the following propounded the critical theory of human rights?
 A) Rousseau B) Gramsci C) Horbeumors D) Thomas Paine
27. Which one of the Directive Principles of state policy under the constitution of India is not related to Human Rights?
 A) Article 39-A B) Article-39 C) Article-43 D) Article-50
28. "Everyone is entitled to a social and international order in which the rights and freedoms set forth in this declaration can be fully realized." This statement is taken from which article of universal declaration of Human Rights?
 A) Article 27 B) Article 28 C) Article 29 D) Article 30
29. In which year I.L.O. was awarded the Noble Prize for Peace in recognition of its activities?
 A) 1989 B) 1979 C) 1969 D) 1999
30. Which of the following is not protected by Right to Privacy?
 A) Identity B) Integrity C) Criminality D) Intimacy
31. Match List – I with List – II and select the correct answer from the codes given below :

List – I

- a) M.C. Mehta v/s. State of T.N.
 b) M.C. Mehta v/s. Union of India
 c) Visakha's case
 d) Maneka Gandhi v/s. Union of India

Codes :

- | | | | | |
|----|----|-----|-----|-----|
| | a | b | c | d |
| A) | iv | iii | ii | i |
| B) | i | ii | iii | iv |
| C) | i | ii | iv | iii |
| D) | ii | i | iv | iii |

List – II

- i. Right to clean environment
 ii. Children's right to education
 iii. Right to life with dignity
 iv. Protection of women at work place

32. Which one of the following is not a UN Agency?
 A) UNICEF B) UNESCO C) WTO D) ILO

33. The legal positivism, a school of thought which does not accept human rights as merely moral or just was propounded by
A) Plato B) Aristotle C) Hegel D) Austin

34. 'Laissez faire' philosophy is an antithesis of
A) Interventionist State B) Repressive State
C) Soft State D) Welfare State

35. **Assertion (A) :** Power of the President to grant pardon and to suspend, remit or commute sentences under Article 72 of the Constitution is politically much abused from the Human Rights point of view.

Reason (R) : The advice given by the Council of Ministers to the President under Article 74 of the Constitution is binding on the President.

Codes :

- A) Both (A) and (R) are correct and (R) is the correct explanation of (A)
- B) Both (A) and (R) are correct but (R) is not the correct explanation of (A)
- C) (A) is correct but (R) is incorrect
- D) (A) is incorrect but (R) is correct

36. Divine attributes to caste:

- A) Provide sense of security
- B) Provide justification for physical alienation
- C) Provide psychological satisfaction about relative superiority
- D) Provide all the above

37. Identify the statement which is not correct?

- A) Medieval age also witnessed anti-caste movements
- B) All caste movements whether pre modern or modern attack on Brahminism
- C) Some new religions have their origin in anti-caste philosophy
- D) None of the above

38. Who of the following headed the committee to study the problems of Unorganized workers in India?

- A) Nitish Sengupta B) Arjun Sengupta
- C) Ravi Shrivastava D) Ashok Mitra

39. Which one of the following writs is issued to Courts, corporations or persons directing them to perform their public duty?

- A) Habeas Corpus B) Quo Warranto C) Mandamus D) Prohibition

40. According to Vandana Shiva by expanding development

- A) Women's economic status would improve
- B) Women's economic status will remain same
- C) Women's economic status will deteriorate
- D) None of the above

41. The maintenance of Internal Security Act was passed in
A) 1950 B) 1971 C) 1963 D) 1991
42. Article 340 of the Indian Constitution deals with
A) Backward Classes Commission
B) Election Commission
C) Union Public Service Commission
D) Finance Commission
43. Movement for Dalit rights was not championed by
A) Sri Narayan Guru
B) Jyotirao Phule
C) Mahadev Ranade
D) B.R. Ambedkar
44. Which schedule of the Indian Constitution provides protection from judicial review to the law passed by legislatures?
A) Fifth Schedule B) Seventh Schedule
C) Ninth Schedule D) Eleventh Schedule
45. Amnesty International is based in which of the following countries?
A) United States
B) United Kingdom
C) United Arab Emirates
D) Canada
46. Sacher Committee Report dealt with the issue of
A) Socio-Economic Development of Muslims
B) All round development of Minorities
C) Amelioration in the conditions of working women
D) Decent and dignified treatment with prisoners of war
47. 'Zakat' as an important aspect of human duties is enunciated in
A) Buddhism B) Islam C) Jainism D) Hinduism
48. Pacific methods of settlement of International disputes do not include
A) Mediation B) Sanction C) Good offices D) Arbitration
49. Name the conference in which the importance of regional arrangements in protection and promotion of human rights was emphasized.
A) Tehran conference B) Vienna conference
C) Helsinki conference D) Rio conference

50. Assertion (A) : Human Rights are largely vertical in nature and are enforceable against the state and thus seek to regulate the relationship between the citizens and the State.

Reason (R): State has come into existence as a result of the agreement or consent of citizens and derives its legitimacy from such agreement.

Codes :

- A) Both (A) and (R) are correct and (R) is the correct explanation of (A)
- B) Both (A) and (R) are correct but (R) is not the correct explanation of (A)
- C) (A) is correct but (R) is incorrect
- D) (A) is incorrect but (R) is correct

x-x-x

Human Genomics(1077)

- In mammalian cells which of the following can transport organic molecules
A) P-type transporters
B) F-type transporters
C) ABC transporters
D) E1-E2 type transporters
- Commensal microbiota provides defence against microorganism invading through
A) Intestine
B) Skin
C) Lungs
D) Gut
- Which of the following phenomenon can cause higher frequency of recessive allele
A) Hetrozygote manifestation
B) Heterozygote advantage
C) Genetic drift
D) Bottleneck
- Mutation rate in humans is
A) 10^{-6} pgpg
B) 10^{-9} pgpg
C) 10^{-3} pgpg
D) 10^{-12} pgpg
- How many generations of random mating is sufficient to establish HWE in the absence of any disturbing factor
A) 01
B) 10
C) 02
D) 100
- The cells which do not divide but can be induced to begin DNA synthesis & divide when given an appropriate stimulus are
A) Stem cells
B) Liver cells
C) Kidney cells
D) Epithelial cells
- D type cyclins bind to cdks during
A) G1-S phase
B) mid- G1 phase
C) G2-M phase
D) Early G1 phase
- 7-TM (Seven transmembrane) receptors are also referred to as
A) RTK receptors
B) GPC receptors
C) Ligand gated channels
D) Steroid hormone receptor
- Glucagon stimulates
A) Lowering of blood sugar
B) Breakdown of glycogen
C) Breakdown of Glucose
D) Biosynthesis of Gylcogen
- Jackknifing is a method for
A) Cluster analysis
B) Validation
C) Phylogeny
D) Homology analysis
- Chronic rejection of a transplant occurs after
A) 02 days
B) 10 days
C) Immediate
D) Months
- Sudden emergence of new subtype of influenza could be due to

- A) Antigenic drift
- B) Antigenic shift
- C) Herd immunity
- D) Unhygienic conditions

13. Philadelphia chromosome represents

- A) Translocation between chr. 8 & 14
- B) Translocation between chr. 9 & 22
- C) Translocation between chr. 9 & 21
- D) Translocation between chr. 8 & 21

14. First eukaryotic genome to be completely sequenced was that of

- A) *S.cerevisiae*
- B) *S. pombe*
- C) *C.elegans*
- D) *D.melanogaster*

15. Restriction enzyme Not I cleaves at 5'-GCGGCCGC-3'. What would be the average distance between cleavage sites on digestion of double stranded DNA

- A) 56 kb
- B) 66 kb
- C) 24 kb
- D) 24 bp

16. Aptamers are

- A) Short peptides
- B) Short RNA sequences
- C) Antibodies
- D) Short PCR products

17. Phenocopy refers to

- A) Genotype along with disease manifestation
- B) Genotype without disease manifestation
- C) Disease manifestation without genotype
- D) Absence of disease and genotype

18. Sickle cell trait allele is a very good example of

- A) Positive selection
- B) Neutral selection
- C) Directional selection
- D) Balancing selection

19. The first fully human antibody (Humira) has been approved for the treatment of

- A) Retinitis pigmentosa
- B) Rheumatoid Arthritis
- C) Cancer
- D) Immunodeficiency

20. Heritability refers to

- A) Total variance that is acquired
- B) Fixed property of trait
- C) Total variance that is genetic
- D) Inheritance of trait

21. When signalling molecule is tethered to transmitting cell surface and is bound by receptor on the surface of responding cell, it is
- A) Autocrine signalling B) Paracrine signalling
C) Synaptic signalling D) Juxtacrine signalling
22. Discovery of which of the following has made the cell based DNA cloning possible
- A) Type I restriction endonuclease B) Type II restriction endonuclease
C) Type III restriction endonuclease D) DNA Taq polymerase
23. Retrogene refers to
- A) Evolutionarily degenerated gene B) Special processed pseudogene
C) Special nonprocessed pseudogene D) Bacterial gene
24. As part of HGP, which of the four model organisms were prioritized for sequencing
- A) *Chlamydomonas*, *S.cerevisiae*, *E.coli*, mouse
B) *E.coli*, mouse, *D. melanogaster*, zebrafish
C) *C.elegans*, *P.falciparum*, *S.pombe*, *Chlamydomonas*
D) *S. cerevisiae*, *E.coli*, *D.melanogaster*, mouse
25. If the probability of being blood type A is $\frac{1}{8}$ and the probability of blood type O is $\frac{1}{2}$, what is the probability of being either blood type A or O?
- A) $\frac{5}{8}$ B) $\frac{1}{8}$ C) $\frac{1}{2}$ D) $\frac{1}{16}$
26. If two proteins have overall sequence identity of 50%, then the overall similarity will be
- A) Less than 50% B) More than 50%
C) Cannot be more than 50% D) Can be less or more than 50%
27. When two oppositely charged groups are close to each other, the interaction is called
- A) Salt bridge B) H-bond
C) Covalent bond D) Triple bond
28. The effective strength of hydrogen bonds will be
- A) Unaffected by water molecules B) Strengthened by water molecules
C) Weakened by water molecules D) Totally destroyed by water molecules
29. Disulfide bond is a
- A) Weak bond B) Covalent bond
C) Non-covalent bond D) A special bond
30. Which of the following is not a unit of structure found in proteins?
- A) β sheets B) α helices C) Loop regions D) γ loops

- 31.** RNA cannot adopt standard Watson-Crick double helical structure because of
- A) Constraints on its sugar pucker B) Absence of thymine
C) Single stranded D) Presence of uracil
- 32.** The DNA double helix is quite
- A) Unstable B) Deformable C) Reactive D) Unstructured
- 33.** Adenosine platform is an
- A) DNA element B) RNA structural motif
C) DNA structural motif D) Protein element
- 34.** An isolated α -helix in water
- A) Will remain as helix B) Will become β -sheet
C) Will be unstable D) Will further compact
- 35.** One amino acid among following usually breaks an alpha helix
- A) Proline B) Glycine C) Leucine D) Valine
- 36.** Upper limit of cell size is probably set by
- A) Rate of diffusion of solute molecules in aq solutions
B) Cell membrane
C) Genes
D) Genome
- 37.** The Adaptor hypothesis by Crick is
- A) About adaptation B) About evolution
C) About tRNA D) About electric circuits
- 38.** In serine proteases, catalytic triad consists of
- A) Serine, glycine, histidine B) Serine, histidine, aspartate
C) Serine, proline, histidine D) Serine, leucine, aspartate
- 39.** If one has to think of conducting a charge, which polymer is useful
- A) Proteins B) DNA C) Polysaccharides D) Lipids
- 40.** Coomassie brilliant blue binds to
- A) Proteins specifically B) Nucleic acids non specifically
C) Proteins nonspecifically D) Nucleic acids specifically

- 41.** Imprinting involves
- | | |
|-----------------------|------------------------|
| A) DNA polymerization | B) DNA phosphorylation |
| C) DNA methylation | D) DNA fragmentation |
- 42.** Evolution is:
- | | |
|-----------------------------|--------------------------|
| A) Directed to a goal | B) An intelligent design |
| C) A random ongoing process | D) Over now |
- 43.** Biological membranes are associated with all of the following except:
- A) Free movement of proteins and nucleic acids across the membrane
 B) Sites for biochemical reactions
 C) Release of protons when damaged
 D) Prevention of free diffusion of ionic solutes
- 44.** Side chain of serine can act as
- | | |
|--------------------|------------------|
| A) An electrophile | B) A nucleophile |
| C) A buffer | D) A hook |
- 45.** The van der Waals radius of an atom is
- | | |
|-------------------------------------|--|
| A) A measure of the size of an atom | B) A measure of the bond that atom forms |
| C) A measure of its charge | D) A measure of its electric field |
- 46.** The only genetically encoded amino acid without a stereoisomer is:
- | | | | |
|------------|---------------|-----------|------------|
| A) Glycine | B) Tryptophan | C) Lysine | D) Proline |
|------------|---------------|-----------|------------|
- 47.** Binomial distribution gives
- A) The probability of events with binary outcomes
 B) The measurement of event in binary digits
 C) Precision of the measurement in binary digits
 D) Accuracy of the measurement in binary digits
- 48.** Which of the following is not a process governed by molecular recognition?
- | | |
|--------------------------------|------------------------------------|
| A) Active transport | B) Passive diffusion |
| C) Translation by the ribosome | D) Transcription by RNA polymerase |
- 49.** Inverted repeat sequences are also called
- | | | | |
|----------------|--------------------|----------------|-------------------|
| A) Palindromes | B) Triplet repeats | C) Nucleosomes | D) Double repeats |
|----------------|--------------------|----------------|-------------------|
- 50.** Which of the following is not involved in the process of translation?
- | | | | |
|----------|---------|---------|---------|
| A) EF-Tu | B) EF-C | C) EF-G | D) RF-3 |
|----------|---------|---------|---------|

x-x-x

Indian Theatre(1077)

- Gautami is a character from Kalidasa's play
A) Malavikagnimitram B) Vikramorvashiyam
C) Abhijyanashakuntalam D) Meghaduta
- Vivek is a character from folk theatre
A) Naqal B) Jatra C) Bhand-Jashna D) Nautanki
- What is Prakarana?
A) Kalpita B) Prakhyata C) Mishra D) None of these
- The movement avant garde originated from which country?
A) Italy B) France C) Germany D) Russia
- Who wrote Shariputrprakarana?
A) Kalidasa B) Bhasa C) Ashvaghosha D) Bhavabhuti
- Who got Magsaysay Award?
A) Utpal Dutt B) Habib Tanvir C) B.V.Karant D) K.V.Subbanna
- The term Verfremdungseffekt is related to
A) Theatre of Cruelty B) Poor Theatre C) Epic Theatre D) Third Theatre
- Pick the odd one out.
A) Hasa B) Sringara C) Vira D) Adbhuta
- Match the List I with List II

List-I

- Nautanki
- Yakshagana
- Kuchipudi
- Vithinatakam

List-II

- Kathakar
- Kaunangi
- Bhagvata
- Ranga

Codes:

- | | | | | |
|----|-------|-------|------|-------|
| | (a) | (b) | (c) | (d) |
| A) | (ii) | (iv) | (i) | (iii) |
| B) | (iv) | (iii) | (ii) | (i) |
| C) | (iii) | (i) | (iv) | (ii) |
| D) | (ii) | (iii) | (i) | (iv) |

10. Match List I with List II

List-I

- a) Vijaya Mehta
- b) Heisnam Kanhailal
- c) Kali Charan Patnaik
- d) Pravin Joshi

List-II

- i) Oriya Theatre
- ii) Marathi Theatre
- iii) Gujarati Theatre
- iv) Manipuri Theatre

Codes:

	(a)	(b)	(c)	(d)
A)	(ii)	(i)	(iii)	(i)
B)	(iii)	(i)	(ii)	(iv)
C)	(ii)	(iv)	(i)	(iii)
D)	(iv)	(iii)	(ii)	(i)

11. Neena Tiwana is bestowed Sangeet Natak Akademy Award for

- A) Direction B) Acting C) Costume Design D) Writing

12. Constructivism a concept in stage design is espoused by

- A) Vsevolod Meyerhold B) AdolpheAppia
C) Gordon Craig D) None of these

13. What is curtain raiser?

- A) Opening of a play performance
B) A song sung before the main play performance
C) A one act play performed before the main play performance
D) All of the above

14. What is empathy?

- A) The act of an audience's identifying with the characters in a play performance.
B) An act of emotional memory of an actor
C) An act of an audience's distancing from a character.
D) None of these

15. Who has coined the term theatre of the absurd?

- A) Samuel Beckett B) EugeneIonesco C) Jean-Paul Sartre D) Martin Esslin

16. The fatal flaw that causes the downfall of the hero of Greek tragedy is known as

- A) Hamartia B) Parados C) Exodos D) None of these

17. What is the objective of grand drape?

- A) It decorates the main curtain of the stage
B) It is used for the masking of the top of the stage
C) It is used for the partition of the stage
D) None of these

18. What is imagery?

- A) Dramatic language
- B) Ornamentation of language
- C) Subtext
- D) Words that paint picture in the mind of the audience

19. Who wrote the book Towards a Revolutionary Theatre?

- A) Badal Sircar
- B) Utpal Dutt
- C) Gursharan Singh
- D) Safdar Hashmi

20. Who is known as the father of Modern Hindi Theatre?

- A) Jaishankar Prasad
- B) Jagdish Chandra Mathur
- C) Bharatendu Harishchandra
- D) Agha Hashr Kashmiri

21. Who was the first director of National School of Drama?

- A) Ebrahim Alkazi
- B) Nemichandra Jain
- C) Sheila Bhatia
- D) Satu Sen

22. Stanislavski theory instructs an actor to read his character in

- A) Second person
- B) First person
- C) Third person
- D) None of these

23. Krishnattam belongs to which state?

- A) Tamilnadu
- B) Orissa
- C) Karnataka
- D) Kerala

24. Match List I with List II.

List-I

- a) Kalidasa
- b) Bhasa
- c) Harsha
- d) Bhavabhuti

List-II

- i) Malatimadhava
- ii) Malavikagnimitram
- iii) Dootavakyam
- iv) Nagananda

Codes:

- | | | | | |
|----|-------|-------|-------|-------|
| | (a) | (b) | (c) | (d) |
| A) | (iv) | (ii) | (i) | (iii) |
| B) | (iii) | (iv) | (ii) | (i) |
| C) | (ii) | (iii) | (iv) | (i) |
| D) | (ii) | (i) | (iii) | (iv) |

25. Match List I with List II.

List-I

- a) Anka
- b) Natika
- c) Prakarana
- d) Nataka

List-II

- i) Malatimadhava
- ii) Malavikagnimitram
- iii) Urubhanagam
- iv) Nagananda

Codes:

	(a)	(b)	(c)	(d)
A)	(ii)	(iii)	(iv)	(i)
B)	(iii)	(iv)	(i)	(ii)
C)	(iv)	(ii)	(iii)	(i)
D)	(i)	(ii)	(iv)	(iii)

26. Match List I with List II.

List-I

- a) Norway
- b) America
- c) Spain
- d) Ireland

List-II

- i) Arthur Miller
- ii) Henrik Ibsen
- iii) Lady Gregory
- iv) Federico Garcia Lorca

Codes:

	(a)	(b)	(c)	(d)
A)	(iii)	(ii)	(i)	(iv)
B)	(iv)	(i)	(iii)	(ii)
C)	(i)	(ii)	(iv)	(iii)
D)	(ii)	(i)	(iv)	(iii)

27. V Ramamurthy is known for

- A) Light Design B) Costume Design C) Set Design D) Make-up

28. A town Ram Nagar in Uttar Pradesh is famous for

- A) Ras Leela B) Ram Leela C) Nautanki D)Swang

29. Which Punjabi playwright and director bestowed Kalidasa Award?

- A) Atamjit B) Kewal Dhaliwal
C) Gursharan Singh D) Ajmer Singh Aulakh

30. Pick the odd one out.

- A) Key Light B) Fill-in Light C) Kick Light D) Flood Light

31. Which of the following are primary colours of light?

- A) Red, Green, Blue B) Red, Yellow, Green
C) Red, Cyan, Yellow D) Green, Blue, Violet

32. Which of the following are elements of design?

- A) Line and Colour B) Line and Texture
C) Tint and Shade D) Line, Colour and Texture

33. Which make-up is used to rectify the defects of an actor's face?

- A) Straight Make-up B) Corrective Make-up
C) Character Make-up D) Fantasy Make-up

- 34.** Who has directed Indian epic Mahabharata?
 A) Peter Brook
 B) Jerzy Grotowski
 C) Vsevolod Meyerhold
 D) Augusto Boal
- 35.** Arms and the Man is written by
 A) Eugene Ionesco
 B) Luigi Pirandello
 C) Maxim Gorky
 D) George Bernard Shaw
- 36.** What is casting?
 A) The process of blocking the scenes
 B) The process of selecting actors for roles
 C) The process of composing the scenes
 D) None of these
- 37.** Which of the following is known as the first theatre director?
 A) Elia Kazan
 B) Emile Zola
 C) Duke Saxe-Meiningen
 D) Erwin Piscator
- 38.** Who has espoused the concept of Third Theatre?
 A) Badal Sircar
 B) Utpal Dutt
 C) Habib Tanvir
 D) B.V.Karant
- 39.** Who has directed play Andha Yug for the first time?
 A) Rajinder Nath
 B) Ebrahim Alkazi
 C) Satyadev Dubey
 D) B.M.Shah
- 40.** Choose the right sequence of the structural graph of a play?
 A) Rising Action, Exposition, Falling Action, Resolution, Climax
 B) Exposition, Rising Action, Climax, Falling Action, Resolution
 C) Resolution, Exposition, Falling Action, Rising Action, Climax
 D) Climax, Exposition, Rising Action, Falling Action, Resolution
- 41.** What is the first step in Research Methodology?
 A) Selecting a sample
 B) Data collection
 C) Writing a research report
 D) Formulating a research problem
- 42.** Who has written and directed the play Chakravayuha?
 A) Ratan Thiyam
 B) Habib Tanvir
 C) B.V.Karant
 D) Alyque Padamsee
- 43.** Pick the odd one out.
 A) Anuradha Kapur
 B) Teejan Bai
 C) Amal Allana
 D) Neelam Man Singh Chowdhary
- 44.** Colour cyan is a mixture of
 A) Red and Blue
 B) Blue and Red
 C) Green and Blue
 D) None of these

45. Globe theatre was built in
A) 1576 B)1558 C)1644 D)1613
46. Which of the following Asian actors helped Brecht to find alienation in acting?
A) Mei Lanfang B) Zeami Motokiyo
C) Tripti Mitra D) Rendra,W.S.
47. Who has introduced the term Epic?
A) Bertolt Brecht B) Aristotle C) Karl Marx D) Hegel
48. What is Plagiarism?
A) Copying B) Cheating C) Stealing D) None of these
49. NCPA is located in
A) Chandigarh B) Calcutta C) Delhi D) Mumbai
50. Who is known as the mother of Indian Opera?
A) Shanno Khurana B) Norha Richards
C) Sheila Bhatia D) Madan Bala Sindhu

x-x-x

1. With increase in impurities in metals, their corrosion resistances
 - A) Increase
 - B) Decrease
 - C) Remain same
 - D) May increase or decrease; depending on the type of metal
2. The most important requirement for aluminium industry is the availability of cheap
 - A) Ore
 - B) Electrical power
 - C) Labour
 - D) Abundant water
3. Neutrons are present in all atoms except that of
 - A) He
 - B) C
 - C) H
 - D) Ar
4. The Fourier number (defined as $a.t/L^2$) is used in the analysis of problem involving heat transfer by
 - A) Forced convection
 - B) Natural convection
 - C) Transient conduction
 - D) Steady state conduction
5. For gases, the thermal conductivity increases with temperature rise. For liquids, with increase in concentration, its thermal conductivity generally
 - A) Decreases
 - B) Increases
 - C) Remains unchanged
 - D) Increases exponentially
6. Among liquids, water has a comparatively high value of thermal conductivity, due to its
 - A) Low density
 - B) High viscosity
 - C) Partial ionisation
 - D) Dense structure
7. Pick out the wrong statement.
 - A) The mole fraction of solute is directly proportional to the molality of a 'dilute' solution
 - B) For a non-reacting binary mixture of ideal gases, the partial pressure distribution of both components is nonlinear in the case of steady state unimolal unidirectional diffusion.
 - C) Azeotropes obey Raoult's law at all temperature.
 - D) The relative volatility of a binary mixture at the azeotropic composition is 1.
8. Leaching of sugar from sugar beets is done by
 - A) Hot water
 - B) Hexane
 - C) Dilute H_2SO_4
 - D) Lime water
9. What is the reflux ratio at total reflux?
 - A) Zero
 - B) Infinity
 - C) Unity
 - D) Data insufficient
10. Commercial fertilisers are available mostly in the form of
 - A) Powder
 - B) Granules
 - C) Lumps
 - D) Flakes
11. Reaction of dilute sulphuric acid with phosphate rock produces

- A) Phosphoric acid B) Superphosphate
C) Triple superphosphate D) Gypsum

12. Liquid ammonia is not used as such a fertiliser in tropical countries like India, because

- A) Its N_2 content is very low B) It is very costly
C) It will evaporate on spraying D) It is not available

13. Internal energy change of a system over one complete cycle in a cyclic process is

- A) Zero B) +ve C) -ve D) dependent on the path

14. Out of the following refrigeration cycles, which one has the minimum COP (Co-efficient of performance)?

- A) Air cycle
B) Carnot cycle
C) Ordinary vapour compression cycle
D) Vapour compression with a reversible expansion engine

15. "At the absolute zero temperature, the entropy of every perfectly crystalline substance becomes zero". This follows from the

- A) Third law of thermodynamics B) Second law of thermodynamics
C) Nernst heat theorem D) Maxwell's relations

16. Which of the following is a thermodynamic property of a system?

- A) Concentration B) Mass C) Temperature D) Entropy

17. While dissolving a gas into a liquid at a constant temperature, the ratio of the concentration of the gas in the solution phase and in the gaseous phase is

- A) Infinity B) Unity C) Constant D) Negative

18. Which of the following exemplifies an adiabatic process?

- A) Melting of ice B) Condensation of alcohol vapor
C) Sudden bursting of a cycle tube D) Evaporation of water

19. During combustion of gaseous fuels, deficiency of air

- A) Lengthens the flame
B) Tends to shorten the flame
C) Does not affect the flame length
D) Increases the flame temperature

20. Low temperature carbonisation

- A) Is mainly for producing the smokeless domestic coke
B) Is meant for the production of 'metallurgical coke'
C) Produces higher quantity of gas than high temperature carbonisation
D) Produces less quantity of tar than high temperature carbonisation

21. Main constituents of purified Lurgi gas are

- A) H_2 , C_mH_n & CO_2 B) CO , H_2 & CH_4
C) CO_2 , O_2 & CO D) N_2 , H_2 & CO_2

22. The cuprous chloride used in orsat apparatus can absorb
A) Only CO
B) Both CO and CO₂
C) Both CO and O₂
D) all CO, CO₂, and O₂.
23. Which of the following is a lean fuel gas?
A) Coke oven gas
B) LPG
C) Blast furnace gas
D) Natural gas
24. Fireclay bricks are not used in the
A) Beehive coke oven
B) By-product coke oven walls
C) Combustion chamber of B.F. stoves
D) Coke oven regenerators.
25. Caprolactum, a raw material for the manufacture of nylon-6, is produced from
A) Phenol B) Naphthalene C) Benzene D) Pyridine
26. The monomer of poly vinyl chloride (PVC) is
A) Chloroethene
B) Ethylene dichloride
C) Ethyl chloride
D) Chloroform
27. Buna-S is also known as
A) Teflon B) PTFE C) SBR D) Polycrylates
28. Automobile steering wheels are normally made of
A) Cellulose acetate
B) Cellulose nitrate
C) PVC
D) High density polythene
29. In a cross linked polymer, the monomeric units are linked together to constitute a three dimensional network. Which of the following is a cross-linked polymer?
A) Bakelite (phenol formaldehyde)
B) Polyester
C) Polythene
D) Nylon-6
30. Polymethyl methacrylate (PMMA) is known as
A) Bakelite B) Teflon C) Perspex D) Nylon-6
31. Neoprene is the trade name of
A) Polyurethane
B) Phenol formaldehyde
C) Polychlorophrene
D) Styrene butadiene rubber (SBR)
32. Epoxy resin is
A) Not used for surface coating
B) A good abrasive
C) An elastomer
D) A polyester
33. The major component of acrylic fibres is
A) Polyamides
B) Polyolefins
C) Polyacrylonitrile
D) Polyesters

34. Which is the most undesirable component in kerosene?
A) Aromatics
B) *i*-paraffins
C) *n*-paraffins
D) Naphthenes
35. Which of the following fractions of a crude oil will have the maximum gravity API (i.e. °API)?
A) Diesel
B) Gasoline
C) Atmospheric gas oil
D) Vacuum gas oil
36. Pour point and freezing point is equal for
A) Petrol
B) Diesel
C) Water
D) Crude petroleum
37. Visbreaking process is used mainly for making
A) High cetane diesel
B) High octane gasoline
C) Fuel oil
D) Smoke free kerosene
38. Stabilisation of gasoline (petrol) means
A) Removal of dissolved gases from it
B) Increasing its oxidation stability
C) Improving its lead susceptibility
D) Increasing its vapour pressure
39. In petroleum refining, the process used for conversion of hydrocarbons to aromatics is
A) Catalytic cracking
B) Catalytic reforming
C) Hydrotreating
D) Alkylation
40. Octane number of gasoline is a measure of its
A) Resistance to knock
B) Ignition delay
C) Ignition temperature
D) Smoke point
41. Catalyst used in catalytic reforming is
A) Platinum on alumina
B) Nickel
C) Iron
D) Aluminium chloride
42. The first crude oil refinery of India is located at
A) Naharkatiya
B) Digboi
C) Kochin
D) Madras
43. Oxidation of SO₂ to SO₃ is favoured by
A) Low temperature and low pressure
B) Low temperature and high pressure
C) High temperature and low pressure
D) High temperature and high pressure
44. Starting raw material for the manufacture of alum is
A) Alumina
B) Gypsum
C) Bauxite
D) Ammonium bicarbonate

45. Salt cake is chemically represented by
A) Na_2SO_4 B) $\text{CaSO}_4 \cdot \frac{1}{2} \text{H}_2\text{O}$ C) MgSO_4 D) BaSO_4
46. Which of the following sugars is the sweetest?
A) Glucose B) Fructose C) Sucrose D) Lactose
47. All enzymes are made of
A) Fats B) Carbohydrates C) Proteins D) Amino acids
48. Styrene is produced from ethyl benzene by the process of
A) Dehydrogenation B) Oxidation
C) Alkylation D) Dehydration
49. Gelatine which is a nitrogenous organic protein is obtained by the hydrolysis of
A) Collagen B) Tannin C) Molasses D) Carbohydrate
50. Haemoglobin is a/an
A) Amino acid B) Biological catalyst
C) Protein D) Enezyme

x-x-x

Information & Technology Engineering(Ph.D.) (1077)

1. The inorder and postorder traversal of a binary tree are:
 $d b e a f c g$ and $a b d e c f g$ respectively
The postorder traversal of the binary tree is:
A) $d e b f g c a$ B) $e d b g f c a$ C) $e d b f g c a$ D) $d e f g b c a$
2. The solution to the recurrence equation $T(2^k)=3T(2^{k-1}) + 1$, $T(1)=1$ is:
A) 2^k B) $(3^{k+1} - 1)/2$ C) $3^{\log_2 k}$ D) $2^{\log_3 k}$
3. If $f(x) = 2x^7 + 3x - 5$, which of the following is a factor of $f(x)$?
A) (x^3+8) B) $(x-1)$ C) $(2x-5)$ D) $(x+1)$
4. Consider an arbitrary set of CPU-bound processes with unequal CPU burst lengths submitted at the same time to a computer system. Which one of the following process scheduling algorithms would minimize the average waiting time in the ready queue?
A) Shortest remaining time first
B) Round-robin with time quantum less than the shortest CPU burst
C) Uniform random
D) Highest priority first with priority proportional to CPU burst length
5. Assume that any vertex v in a graph is connected to itself. Then the relation R defined by $u R v$ if and only if u is connected to v on a graph G is
A) Symmetric and transitive only
B) Not reflexive
C) An equivalence relation
D) A partial ordering relation
6. Let T be a binary search tree with 15 nodes. The maximum and minimum possible heights of tree T are: (ASSUMING tree with single node has height 0)
A) 15, 4 B) 14, 3 C) 14, 4 D) 15, 3
7. Threads of a process share with each other:
A) Global variables only B) Heap only
C) Both global variables and heap D) Neither global variables nor heap
8. In a quadratic function, the value of the product of the roots (α, β) is 4. Find the value of $(\alpha^n + \beta^n) / (\alpha^{-n} + \beta^{-n})$
A) n^4 B) 4^n C) 2^{2n-1} D) 4^{n-1}
9. Which of the following statements is false:
A) If λ is an eigen value of a non-singular matrix A , then $1/\lambda$ is an eigen value of A^{-1}
B) The sum of eigen values of a matrix A equals the trace of A
C) If A is invertible then trace of ACA^{-1} equals the trace of C
D) For any constant k , trace of kA =trace of A

10. A database of research articles in a journal uses the following schema:

(VOLUME, NUMBER, STARTPAGE, ENDPAGE, TITLE, YEAR, PRICE)

The primary key is (VOLUME, NUMBER, STARTPAGE, ENDPAGE) and the following functional dependencies exist in the schema:

(VOLUME, NUMBER, STARTPAGE, ENDPAGE) → TITLE

(VOLUME, NUMBER) → YEAR

(VOLUME, NUMBER, STARTPAGE, ENDPAGE) → PRICE

The database is redesigned to use the following schemas.

(VOLUME, NUMBER, STARTPAGE, ENDPAGE, TITLE, PRICE)

(VOLUME, NUMBER, YEAR)

Which is the weakest normal form that the new database satisfies, but the old one does not?

A) 1NF

B) 2NF

C) 3NF

D) BCNF

11. Given that p the probability of a page fault in a system is close to zero, that is there are only few page faults. If the average page fault service time is 25 milliseconds and memory access time is 100 nanoseconds, then which of the following denotes the effective access time in nanoseconds?

A) $100 + 24,999,900 \times p$

B) $24,999,990 \times p$

C) $100 + 25,999,990 \times p$

D) $100 + 25,000,000 \times p$

12. Consider the following C program:

```
void f(char *a)
{
a=(char *) malloc (10*sizeof (char));
strcpy (a, "HELLO");
}
int main ()
{
char *str = "HI";
f(str);
printf("%s", str);
}
```

What will be printed for the above C program:

A) HI

B) HELLO

C) HELLOHI

D) Segmentation fault

13. What is the function of the preamble in an Ethernet network?

A) Clock Synchronization

B) Error Checking

C) Collision Avoidance

D) Broadcast

14. The following postfix expression with single digit operands is evaluated using a stack

$8\ 2\ 3\ ^\ / \ 2\ 3\ * \ + \ 5\ 1\ * \ -$

The top two elements of the stack after the first $*$ is evaluated are:

A) 6,1

B) 5,7

C) 3,2

D) 1,5

(2)

15. Consider a hash table of size seven, with starting index zero, and a hash function $(3x+4)\text{mod } 7$. Assuming the hash table is initially empty, which of the following are the contents of the table when the sequence 1, 3, 8, 10 is inserted into the table using closed hashing? Note that – denotes an empty location in the table

- A) 8, -, -, -, -, -, 10
 B) 1, 8, 10, -, -, -, 3
 C) 1, -, -, -, -, -, 3
 D) 1, 10, 8, -, -, -, 3

16. The Address Resolution Protocol translates:

- A) A physical address into a hardware address
 B) An IP address into a logical address
 C) A hardware address into a physical address
 D) An IP address into a hardware address

17. What is the time complexity of the following recursive function:

```
int func (int n) {
  if (n<=2)
  else return 1 :
  return (func (floor (sqrt (n)) + n);
```

- A) $\Theta(n^2)$ B) $\Theta(n \log_2 n)$ C) $\Theta(\log_2 n)$ D) $\Theta(\log_2 \log_2 n)$

18. Which one of the following statements is false:

- A) Any relation with two attributes is in BCNF
 B) A relation in which every key has only one attribute is in 2NF
 C) A prime attribute can be transitively dependent on a key in a 3NF relation
 D) A prime attribute can be transitively dependent on a key in a BCNF relation

19. Consider the following schedule involving two transactions. Which one of the following statements is true?

S_1 : $r_1(X)$; $r_1(Y)$; $r_2(X)$; $r_2(Y)$; $w_2(Y)$; $w_1(X)$
 S_2 : $r_1(X)$; $r_2(X)$; $r_2(Y)$; $w_2(Y)$; $r_1(Y)$; $w_1(X)$

- A) Both S_1 and S_2 are conflict serializable
 B) S_1 is conflict serializable but not S_2
 C) S_1 is not conflict serializable but S_2 is conflict serializable
 D) Both S_1 and S_2 are not conflict serializable

20. For which of the following reasons does IP use the TTL field in the IP datagram header?

- A) Ensure packet reaches destination within that time
 B) Discard packets that reach later than that time
 C) Prevent packets from looping indefinitely
 D) Limit the time for which a packet gets queued in routers

21. A minimum state deterministic finite automaton accepting the language

$L = \{w \mid w \in \{0,1\}^*, \text{ number of 0s and 1s in } w \text{ are divisible by 3 and 5, respectively}\}$ has

- A) 15 states B) 11 states C) 10 states D) 9 states

22. How many different non isomorphic Abelian groups of order 4 are there?

- A) 2 B) 3 C) 4 D) 5

23. Let L_1 be a regular language, L_2 be a deterministic context free language and L_3 a recursively enumerable, but not recursive language. Which one of the following statements is false?
- A) $L_1 \cap L_2$ is a deterministic CFL
 B) $L_3 \cap L_1$ is recursive
 C) $L_1 \cup L_2$ is context free
 D) $L_1 \cap L_2 \cap L_3$ is recursively enumerable
24. Consider the following propositional statements:
 P1: $((A \wedge B) \rightarrow C) \equiv ((A \rightarrow C) \wedge (B \rightarrow C))$
 P2: $((A \vee B) \rightarrow C) \equiv ((A \rightarrow C) \vee (B \rightarrow C))$
 Which one of the following is true:
- A) P1 is a tautology, but not P2
 B) P2 is a tautology, but not P1
 C) P1 and P2 are both tautologies
 D) Both P1 and P2 are not tautologies
25. Let S be an NP complete problem and Q and R be two other problems not known to be in NP. Q is polynomial time reducible to S and S is polynomial time reducible to R. Which of the following statements is true?
- A) R is NP complete
 B) R is NP hard
 C) Q is NP complete
 D) Q is NP hard
26. Karnaugh map is used to
- A) Minimize the number of flip flops in a digital circuit
 B) Minimize the number of gates only in a digital circuit
 C) Minimize the number of gates and fan-in of a digital circuit
 D) Design gates
27. $(FE35)_{16} \text{ XOR } (CB15)_{16}$ is equal to
- A) $(3320)_{16}$ B) $(FF35)_{16}$ C) $(FF50)_{16}$ D) $(3520)_{16}$
28. Let $G_1=(V, E_1)$ and $G_2=(V, E_2)$ be connected graphs on the same vertex set V with more than two vertices. If $G_1 \cap G_2=(V, E_1 \cap E_2)$ is not a connected graph, then the graph $G_1 \cup G_2=(V, E_1 \cup E_2)$
- A) Cannot have a cut vertex
 B) Must have a cycle
 C) Must have a cut-edge
 D) Has chromatic number strictly greater than those of G_1 and G_2
29. The language $\{a^m b^n c^{m+n} \mid m, n \geq 1\}$ is
- A) Regular
 B) Context free but not regular
 C) Context sensitive but not context free
 D) Type 0 but not context sensitive
30. In a negative edge triggered J-K flip-flop, in order to have the output Q state 0,0 and 1 in the next three successive clock pulses, the J-K input states required would be respectively
- A) 00, 01 and 10
 B) 00, 01 and 11
 C) 00, 10 and 01
 D) 01, 10 and 11

31. The number of comparators needed in a 4 bit flash type A/D converter is
 A) 32 B) 15 C) 8 D) 4
32. What does the following C statement declare?
`int (* f) (int *);`
 A) A function that takes an integer pointer as argument and returns an integer
 B) A function that takes an integer as argument and returns an integer pointer
 C) A pointer to a function that takes an integer pointer as argument and returns an integer
 D) A function that takes an integer pointer as argument and returns a function pointer
33. The time complexity of computing the transitive closure of a binary relation on a set of n -elements is known to be:
 A) $O(n)$ B) $O(n \log n)$ C) $O(n^{3/2})$ D) $O(n^3)$
34. Packets in the same session may be routed through different paths in:
 A) TCP, but not UDP B) TCP and UDP
 C) UDP, but not TCP D) Neither TCP nor UDP
35. An organization has a class B network and wishes to form subnets for 64 departments. The subnet mask would be:
 A) 255.255.0.0 B) 255.255.64.0 C) 255.255.128.0 D) 255.255.252.0
36. Consider the grammar
 $S \rightarrow (S) \mid a$
 Let the number of states in SLR(1), LR(1) and LALR(1) parsers for the grammar be n_1 , n_2 and n_3 respectively. The following relationship holds good:
 A) $n_1 < n_2 < n_3$ B) $n_1 = n_3 < n_2$ C) $n_1 = n_2 = n_3$ D) $n_1 \geq n_3 \geq n_2$
37. Consider a direct mapped cache of size 32 KB with block size 32 bytes. The CPU generates 32 bit addresses. The number of bits needed for cache indexing and the number of tag bits are respectively:
 A) 10, 17 B) 10, 22 C) 15, 17 D) 5, 17
38. In a packet switching network, packets are routed from source to destination along a single path having two intermediate nodes. If the message size is 24 bytes and each packet contains a header of 3 bytes, then the optimum packet size is:
 A) 4 B) 6 C) 7 D) 9
39. Suppose the round trip propagation delay for a 10 Mbps Ethernet having 48-bit jamming signal is 46.4 microseconds. The minimum frame size is:
 A) 94 B) 416 C) 464 D) 512
40. A 4-bit synchronous counter uses flip-flops with propagation delay time of 15 ns each. The maximum possible time required for change of state will be
 A) 15ns B) 30ns C) 45ns D) 60ns

41. Which of the following sorting algorithms has the lowest worst case complexity?
 A) Merge sort B) Bubble sort C) Quick sort D) Selection sort
42. A critical section is a program segment
 A) Which should run in a certain specified amount of time
 B) Which avoids deadlocks
 C) Where shared resources are accessed
 D) Which must be enclosed by a pair of semaphore operations, p and v
43. Booth's algorithm for larger multiplication gives worst performance when the multiplier pattern is
 A) 101010....1010 B) 1000....0001 C) 1111....1111 D) 0111...1110
44. Consider a system having M resources of the same type. These resources are shared by 3 processes A, B and C which have peak demands of 3,4 and 6 respectively. For what value of M deadlock will not occur?
 A) 7 B) 9 C) 10 D) 13
45. For a random listing of the letters A, B, C and D, find the mean and the variance of the number of pairs of letters out of order.
 A) Mean= 3, Variance=13/6 B) Mean= 13, Variance=3/6
 C) Mean= 2, Variance=12/6 D) Mean= 2, Variance=13/6
46. Which of the following best describes a use case?
 A) It is text describing in detail one flow of events through a real situation
 B) It is the system specification problem statement
 C) It is text which describes the dialogue between actors and the system
 D) It is a diagram drawn to illustrate how cases and actors interact by sending stimuli to one another
47. In distance vector routing, each router receives vectors from
 A) Every router in the network B) Every router less than two units away
 C) A table stored by the software D) Its neighbours only
48. Which of the following is not a data mining functionality?
 A) Characterization B) Outlier Analysis C) Selection D) Classification
49. The purpose of data integration is to:
 A) Data cleaning B) Analysing Data
 C) Unify data into a common schema D) Data reduction
50. The correct term used to describe a type of malicious software designed to block access to a computer system until a sum of money is paid is:
 A) Trojan B) Ransomware C) Phishingware D) Botnet

x-x-x

Mass Communication(Ph.D.)

1. A story that attempts to correct a previous story without indicating that the prior story had been in error or without taking responsibility for the error.
A) Running story B) Rowback C) Sidebar D) Roundup
2. An uninterrupted transition from one sound to another is called
A) Segue B) Zooming C) Outtakes D) Cutaway
3. Early edition, usually the first of a newspaper is called
A) New edition B) B-copy C) Bulldog edition D) Current edition
4. In development communication the focus is on
A) Determining the needs of the people and giving credibility to the expression of those needs
B) Raising people's awareness of development projects and opportunities
C) Helping foster attitudes that contribute to development and motivation
D) All of the above
5. The verb "cover" in reference to newspapers and magazines means to
A) Include a wide variety of items in an article
B) Research and write a story
C) Cover up the facts while writing a story
D) Write a story for the front cover
6. A produced news package with a live shot, a live intro, and tag is called
A) Donut B) Downcut C) Cold copy D) B-Roll
7. On a newspaper website, text
A) Should be stacked in narrow legs like a conventional newspaper
B) Should be formatted in one wide column
C) Should run to several paragraphs on a home page
D) None of the above
8. 'P' in USP refers to
A) Promise B) Proposition C) Propaganda D) None of these
9. A person who posts to an online forum or blog with the sole aim to provoke a hostile response from other readers. What is this person called?
A) Dissenter B) Troll C) Unique visitor D) Web surfer
10. This is a website or a web application that seamlessly combines content from more than one source into an integrated experience. What is it called?
A) Masthead B) Metadata C) Mashup D) MySQL
11. Which one of the following is NOT a device for propaganda?
A) Selective Campaigning B) Name Calling

- 20.** To understand a research problem if the researcher combines qualitative and quantitative techniques, it is known as
- A) Sociogram
 - B) Binary method
 - C) Triangulation
 - D) Evaluation
- 21.** The term 'weight' in a newspaper design means
- A) Physical weight
 - B) Light weight
 - C) Story weight
 - D) Optical weight
- 22.** The phenomenon stimulated in response to media celebrities, implying intense attachment to and involvement in the achievements and personal lives of star performers, especially in music and popular entertainment is
- A) Framing
 - B) Fandom
 - C) Meme
 - D) Sensationalism
- 23.** Which committee was constituted to study the law relating to Contempt of Court?
- A) Sarkaria Committee
 - B) Sawant Committee
 - C) Sanyal Committee
 - D) Verghese Committee
- 24.** In the field of research, the premise is that the simplest method is the most preferable. What is it called?
- A) Ockham's Razor
 - B) Golden mean
 - C) Quota sample
 - D) Purposive sample
- 25.** The set of characteristics that most accurately describe Public Relations is
- A) Low cost, high credibility, low control
 - B) High cost, high credibility, low control
 - C) High cost, low credibility, high control
 - D) Low cost, low credibility, high control
- 26.** 'Hammocking' as the Prime Time scheduling strategy refers to
- A) Sandwiching a weak programme between two successful programmes
 - B) Sandwiching a successful programme between two weak programmes
 - C) One genre of programmes
 - D) None of the above
- 27.** According to the Law of Defamation, those words will be deemed to be defamatory which
- A) Expose the plaintiff to hatred, contempt, ridicule, obloquy
 - B) Tend to injure him in his profession or trade
 - C) Cause him to be shunned or avoided by his neighbours
 - D) All of the above

- 28.** It is helpful to use a multi-stage cluster sample when:
- A) The population is widely dispersed geographically
 - B) You have limited time and money available for travelling
 - C) You want to use a probability sample in order to generalise the results
 - D) All of the above
- 29.** Which one of the following is NOT a basic object of the Right to Information Act?
- A) To empower the citizens
 - B) To promote transparency and accountability in the working of the Government,
 - C) To maintain the security of the State against leakage of secret documents
 - D) To make our democracy work for the people in real sense
- 30.** A 'construct' is a combination of:
- A) Variables
 - B) Hypothesis
 - C) Concepts
 - D) Control factors
- 31.** One-tailed test and two-tailed test are related to:
- A) Concepts
 - B) Constructs
 - C) Causation
 - D) Hypothesis
- 32.** The central theme of an advertisement that motivates the consumer to make a purchase decision is?
- A) Advertising appeal
 - B) Advertisement script
 - C) Slogan
 - D) Headline
- 33.** One of the following methods is NOT used to evaluate advertising effectiveness. Which is it?
- A) Pre- test
 - B) Post- test
 - C) Concurrent test
 - D) Marginal test
- 34.** Which of the following is accomplished by Point-of-purchase displays for retailers?
- A) Extend the amount of time consumers spend in the store
 - B) Deliver useful information and simplify the consumer shopping process
 - C) Reinforce the brand image
 - D) Encourage consumers to switch brands
- 35.** What two forms of search engine advertising are available to online advertisers?
- A) Wired and wireless
 - B) Internet and intranet
 - C) Keyword matching and content targeted
 - D) Click-through and banner ads
- 36.** Diffusion of Innovations Theory was given by
- A) Paul Lazarsfeld
 - B) George Gerbner
 - C) Jorge Comstock
 - D) Everett Rogers

- 37.** In journalism, “convergence” means
- A) Sharing facilities, newsgathering resources, personnel or content
 - B) Different news media all cover the same story in the same way
 - C) The content of one newspaper is indistinguishable from that of any other newspaper
 - D) News organizations are all striving to put the same ideological slant on news stories
- 38.** In journalism, a “mojo” is a
- A) Journalist who has an unusual degree of sex appeal
 - B) A source who provides a journalist with a good-luck charm
 - C) A source who has the ability to bounce back from adversity
 - D) Journalist who carries her tools- computers, cameras, recorders- with her at all times
- 39.** What effect does increasing the sample size have upon the sampling error?
- A) It reduces the sampling error
 - B) It increases the sampling error
 - C) It has no effect on the sampling error
 - D) None of these
- 40.** One job of the gatekeeper is to determine
- A) The amount of feedback that returns to the source of a media message
 - B) How messages to consumers are constructed
 - C) How mass communication affects interpersonal communication
 - D) How ratings data will be interpreted by media
- 41.** The conflict of interest between media who want to cover a trial, and a defendant who wants a fair trial, is an example of
- A) An impact issue
 - B) An ethical issue
 - C) A legal issue
 - D) A moral issue
- 42.** A deductive theory is one that
- A) Allows theory to emerge out of the data
 - B) Involves testing an explicitly defined hypothesis
 - C) Allows for findings to feed back into the stock of knowledge
 - D) Uses qualitative methods whenever possible
- 43.** According to Agenda-Setting Theory, the media influences the public agenda by
- A) Giving more exposure to particular topics
 - B) Telling the audience that a topic is good or bad
 - C) Offering all sides and opinions of the issue
 - D) Polling viewers and readers about their opinions

- 44.** Cultivation Theory considers the media's impact on
- A) Our perceptions about the social world
 - B) Our beliefs about what is most important
 - C) Our attitudes towards social issues
 - D) Our willingness to act on persuasive messages
- 45.** In studying how media's influence is affected by people's intelligence and education, individual differences theory is an example of the era of
- A) Mass Society Theory
 - B) Cultural Theory
 - C) Limited Effects
 - D) The scientific perspective on mass communication theory
- 46.** Why do qualitative researchers like to give detailed descriptions of social settings?
- A) To provide a contextual understanding of social behaviour
 - B) Because once they have left the field, it is difficult to remember what happened
 - C) So that they can compare their observations as a test of reliability
 - D) Because they do not believe in going beyond the level of description
- 47.** Freedom of speech increases the controversial nature of media ethics because
- A) Some countries don't encourage freedom of speech
 - B) Media ethics deals with voluntary conduct
 - C) Many people feel free to speak out against ethics
 - D) None of the above
- 48.** The term "checkbook journalism" refers to the practice of
- A) Paying a reporter to create a fictional story
 - B) Bribing a reporter to suppress an unflattering story
 - C) Paying the salaries of the staff of a tabloid
 - D) Paying for an actual news story
- 49.** Which of the following suggestions should a broadcast news writer NOT follow?
- A) Avoid complicated syntax and keep your subjects and verbs close together
 - B) Limit sentences to 20 words or less
 - C) Use the inverted pyramid format
 - D) It's OK to start sentences with conjunctions
- 50.** Following a guideline for truth-telling can be complicated for journalists because
- A) Advertisers sometimes play fast and loose with the truth
 - B) Many journalists have no interest in adhering to the truth
 - C) It is sometimes hard to agree on what the truth is
 - D) They are trying to tell an artistic truth, rather than a historical truth

- A) Delhi High Court B) FSSAI C) Supreme Court D) None of these
- 13.** Which amongst the following amendment Act recently makes it mandatory for every establishment having 50 or more employees to provide crèche facilities.
- A) Factories (Amendment) Act
 B) The maternity Benefit (Amendment) Act
 C) The domestic violence (Amendment) Act
 D) None of the above
- 14.** In State of Telangana Vs. Habib Abdullaha, it was held :-
- A) Police have no right to investigate unless judiciary gives directions
 B) Police has statutory right to investigate without any interference or directions from judiciary
 C) Police to upload FIR within 24 hours of its registration
 D) None of the above
- 15.** Which of the following is not an eligibility criterion for election of President of India.
- A) Should of the citizen of Indian
 B) Should be elected member of the house of people
 C) Should be atleast 35 years of age
 D) Should be qualified for election to the house of people
- 16.** The international court of justice, India is contesting the death penalty given by Pakistan to which Indian National.
- A) Kulbushan Jadhav B) Kahmir Singh Jadhav
 C) Sheikh Nabi Ahmed D) Chander Charan
- 17.** Goods and Services Tax, 2017 (GST) is proposed to come into effect / has come into effect from
- A) 1st July 2017 B) 31st July 2017 C) 21st July 2017 D) None of these
- 18.** Regarding the issue of National Anthem being played in Cinema Halls, Supreme Court of India has clarified in February, 2017 that
- A) Audience need not stand when National Anthem is a part of documentary or film
 B) Audience need to stand when National Anthem is played even in films
 C) Government need to frame guidelines
 D) None of the above
- 19.** In which of the following case Supreme Court held that seeking votes in election in the name of religion is a corrupt practice
- A) Abhiram Singh Vs. CD Commachen and ors
 B) Vijendra Singh vs. State of Uttar Pradesh
 C) Sheikh Abdul vs. State of Uttar Pradesh
 D) None of the above
- 20.** Constitution Day also known as Samvidhan divas is celebrated in India every year on
- A) 5th June B) 26th November C) 10th December D) 26th January
- 21.** Under the theory of Parliamentary Sovereignty
- A) The democracy is limited
 B) The courts cannot question the laws made by the parliament
 C) Fundamental right cannot be protected / guaranteed
 D) Parliament is not responsible to the people

22. "The basic structure of the constitution could not be abrogated even by the constitutional Amendment". This decision is the outcome of which of the below cases?
 A) Golaknath vs. State of Punjab - AIR 1976 SC 1643
 B) Indira Gandhi vs. Raj Narain – 1976 Vol.(2) SCR 347
 C) Kesavananda Bharti vs. State of Kerala - AIR 1973 SC 1461
 D) None of the above
23. In which of the following cases has the power of Judicial Review of the constitution Amending Act been nullified by the Supreme Court ?
 A) Golaknath vs. State of Punjab - AIR 1976 SC 1643
 B) Minerva Mills Ltd and ors vs. Union of India and ors - AIR 1980 SC 1789
 C) Kesavananda Bharti vs. State of Kerala - AIR 1973 SC 1461
 D) None of the above
24. Every Proclamation under Article 352 may get a fresh lease of _____ months from the date it is approved by the resolution of both the House of Parliament
 A) Three B) Six C) One and Half D) Two
25. When President is impeached for violation of Constitution, the charges shall be preferred by _____ of the Parliament
 A) Lok Sabha B) Rajya Sabha C) Either House D) None of them
26. Article 370 of the Constitution of India
 A) Is permanent in nature
 B) Was a temporary solution until the Constituent Assembly made its decision
 C) Was a temporary solution until the State was integrated with India
 D) Was a temporary solution until the hostility in the region ceases
27. A marriage without requisite ceremonies under Hindu Marriage Act is
 A) Null and void B) Voidable
 C) Irregular D) None of these
28. The starting point the definition of cruelty was made in the following case.
 A) Russel Vs. Russel B) Cooper Vs. Cooper
 C) Dastance Vs. Dastance D) None of these
29. Under the Hindu Adoption and Maintenance Act 1956 the ceremony required is
 A) Datta Homan B) Giving and Taking
 C) Both (A) and (B) D) None of these
30. Hanuman Prasad Panday Vs. MST Baboee is the case related to
 A) Adoption B) Guardian Ship
 C) Marriage D) Succession
31. T. Sareetha vs. Venkatsubbaiah isa case relating to
 A) Partition of property B) Conjugal right
 C) Inheritance D) None of these
32. Which one of the Hindu succession Act, 1956 makes provision for notional partition?
 A) Section 10 B) Section 14 C) Section 6 D) Section 18

- 33.** A Surety may be discharged from his liability
 A) By variance in the terms of contract
 B) By release of discharge of principal debtor
 C) By loss of surety by the creditor
 D) All of the above
- 34.** When the parties to a contract agree to substitute the existing contract for new contract, it is called
 A) Novation B) Alteration C) Rescission D) All of these
- 35.** A right to sue on quantum meruit arises
 A) When a party has fully performed the contract
 B) When a party has partly performed the contract and is discharge because of breach of contract by another party
 C) When contract is discharge by impossibility of performance
 D) All of these
- 36.** Consideration in case of contract
 A) Must have some value in the eyes of law B) Must be real
 C) Must not be illusory D) All are correct
- 37.** An agent was directed by principal to store the goods in godown 'A'. But the agents stores the goods in godown 'B'
 A) Agent will be liable for accidental loss to the goods only when negligence can be proved on his part.
 B) Agent will be liable for accidental loss to the goods even when no negligence can be proved
 C) Agent will not be liable for loss to goods
 D) None of the above
- 38.** Promissory estoppels is sometimes spoken as a substitute for
 A) Novation B) Quasi contract C) Consideration D) Coercion
- 39.** as defined in IPC means use of force or violence by an un lawful assembly or by any member there of in prosecution of common object of that assembly.
 A) Unlawful assembly B) Rioting
 C) Affray D) Dacoity
- 40.** Dacoity is committed.
 A) When two or more persons commits or attempt to commit robbery
 B) When five or more persons conjointly commits or attempts to commit robbery
 C) When theft is committed with fire arms or lethal weapon
 D) When seven or more persons are engaged in an incident
- 41.** In criminal law, the successful prosecution means
 A) Acquittal of the accused
 B) Conviction of the accused
 C) The accused is discharged unconditionally
 D) Punishment to the accused as per law

42. If a citizen of India commits any offence outside India he
- Cannot be prosecuted in India, as the act was not committed in India
 - Can be prosecuted in a country where offence was committed
 - Can be prosecuted in India in any place in which he may be found
 - Cannot neither be prosecuted in India nor in a country where the crime was committed?
43. Which of the following is not essential in case of offence of kidnapping
- Minor Child
 - Intention of the accused
 - Without the permission of lawful guidance
 - None of the above
44. Punishment for being a member of unlawful assembly under Indian Penal Code has been provided under
- Section 141
 - Section 142
 - Section 143
 - Section 146
45. Robert Nozick's proposes the formula $r \times H$ as a guide to determine the appropriate punishment. What does it mean?
- Effectiveness of rehabilitation multiplied by Hazard to the community
 - Extent of responsibility multiplied by actual Harm done
 - Risk of violence multiplied by degree of Humility of offender
 - Recidivism multiplied by defendant's History
46. Legal Realism is the theory of law according to which 'law is the _____ of court
- Wisdom
 - Understanding
 - Practice
 - Weapon
47. Which position does Rawls claim is the least likely to be adopted by the POP (people in the original position)?
- The POP would choose equality above liberty
 - The POP would opt for the 'maximin' strategy
 - The POP would opt for the 'difference principle'
 - The POP would reject the 'system of natural liberty.'
48. What is analytical jurisprudence?
- The critical analysis of legal decisions
 - A sociological method to analyse legal systems
 - The study of what the law is
 - None of above
49. What is Utilitarianism?
- A philosophical approach according to which laws are valid only if they benefit the greater good
 - The idea that all individuals should benefit equally from law's usefulness
 - The idea that the collective good prevails over individual rights
 - None of these
50. Person in "Possession" has better title against the whole world except the real owner. This principle has been illustrated in which of the following case?
- Armory vs. Delamirie
 - Bridges vs. Howkes worth
 - R vs. Moor
 - Re Cohen's Case

25. Match the following

- | | |
|---------------------|-------------------------------|
| a) Reversible cycle | 1. Measurement of temperature |
| b) Mechanical work | 2. Clausius Theorem |
| c) Zeroth Law | 3. Inexact differential |
| d) Heat | 4. High grade energy |

- | | | | | |
|----|---|---|---|---|
| | a | b | c | d |
| A) | 2 | 3 | 1 | 4 |
| B) | 2 | 4 | 1 | 3 |
| C) | 3 | 4 | 1 | 2 |
| D) | 2 | 4 | 3 | 1 |

26. A superheated Rankine Cycle is shown in the given T-S diagram. Starting from the feed pump, the fluid flow upto the boiler exit is represented by state-line

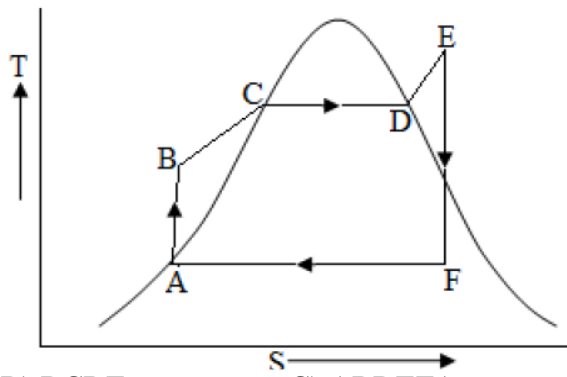

- A) ABCD B) BCDE C) ABDEFA D) ABCDE

27. The compression ratio of a gas power plant cycle corresponding to maximum work output for the given temperature limits of T_{\min} and T_{\max} will be

- A) $\left(\frac{T_{\max}}{T_{\min}}\right)^{\frac{\gamma}{2(\gamma-1)}}$ B) $\left(\frac{T_{\min}}{T_{\max}}\right)^{\frac{\gamma}{2(\gamma-1)}}$ C) $\left(\frac{T_{\max}}{T_{\min}}\right)^{\frac{\gamma-1}{\gamma}}$ D) $\left(\frac{T_{\min}}{T_{\max}}\right)^{\frac{\gamma-1}{\gamma}}$

28. A company has an annual demand of 1000 units, ordering cost of Rs. 100/order and carrying cost of Rs. 100/unit/year. If the stock-out costs are estimated to be nearly Rs. 400 each time the company runs out-of-stock, the safety stock justified by the carrying cost will be

- A) 4 B) 20 C) 40 D) 100

29. Match the following:-

- | | NC Code | Definition |
|----|---------|-------------------------------|
| a) | M05 | 1. Absolute coordinate system |
| b) | G01 | 2. Dwell |
| c) | G04 | 3. Spindle stop |
| d) | G90 | 4. Linear interpolation |

	a	b	c	d
A)	2	3	4	1
B)	3	4	1	2
C)	3	4	2	1
D)	4	3	2	1

30. A robot arm PQ with end coordinates P (0, 0) and Q (2, 5) rotates counter clockwise about P in the XY plane by $90^\circ C$. The new coordinate pair of the end point Q is
- A) (-2, 5) B) (-5, 2) C) (-5, -2) D) (2, -5)
31. Holes in Nylon button are made by
- A) EDM B) CHM C) USM D) LBM
32. In a DC arc welding operation, the voltage-Arc length characteristic was obtained as $V_{arc} = 20 + 5L$ where the arc length 'L' was varied between 5 mm and 7 mm. Here V_{arc} denotes the arc voltage in volts. The arc current was varied from 400 A to 500 A. Assuming linear power source characteristic, the open circuit voltage and short circuit current for the welding operation are
- A) 45 V, 450 A B) 75 V, 750 A C) 95 V, 950 A D) 150 V, 1500 A
33. In a sand casting operation, the total liquid head is maintained constant such that it is equal to the mould height. The time taken to fill the mould with a top gate is t_A . If the same mould is filled with a bottom gate, then the time taken is t_B . Ignore the time required to fill the runner and frictional effects. Assume atmospheric pressure at the top molten metal surfaces. The relation between t_A and t_B is:
- A) $t_B = \sqrt{2} t_A$ B) $t_B = 2t_A$ C) $t_B = \frac{t_A}{\sqrt{2}}$ D) $t_B = 2\sqrt{2} t_A$
34. Tap, dies and drills contain carbon
- A) Below 0.5% B) Below 1% C) Above 1% D) Above 2%
35. A room contains 40 kg of dry air and 0.5 kg of water vapour. The total pressure and temperature of air in the room are 100 kPa and $27^\circ C$ respectively. Given that the saturation pressure for water at $27^\circ C$ is 3.2 kPa, the relative humidity of the air in the room is
- A) 64.32% B) 52.34% C) 61.56% D) 67.36%
36. For a completely submerged body with centre of gravity 'G' and centre of buoyancy 'B', the condition of stability will be
- A) G is located below B B) G is located above B
C) G and B are coincident D) independent of the locations of G and B

37. A rectangular water tank, full to the brim, has its length, breadth and height in the ratio of 2: 1: 2. The ratio of hydrostatic forces at the bottom to that at any larger vertical surface is:

- A) $\frac{1}{2}$ B) 1 C) 2 D) 4

38. Which non-dimensional number relates the thermal boundary layer and hydrodynamic layer?

- A) Rayleigh number B) Peclet number
 C) Grashof number D) Prandtl number

39. Match the following

List - I

- a) Schmidt number
 b) Thermal diffusivity
 c) Lewis number
 d) Sherwood number

List - II

1. $\frac{k}{\rho C_p D}$
 2. $\frac{h_m L}{D}$
 3. $\frac{\mu}{\rho D}$
 4. $\frac{k}{\rho C_p}$

- | | | | | |
|----|---|---|---|---|
| | a | a | a | d |
| A) | 4 | 3 | 2 | 1 |
| B) | 4 | 3 | 1 | 2 |
| C) | 3 | 4 | 2 | 1 |
| D) | 3 | 4 | 1 | 2 |

40. In a counter flow heat exchanger, the product of specific heat and mass flow rate is same for hot and cold fluids. If NTU is equal to 0.5, then the effectiveness of the heat exchanger is

- A) 1.0 B) 0.5 C) 0.33 D) 0.2

41. The cubic capacity of 4-stroke over square S.I. engine is 300 cm^3 . The ratio of stroke to bore is 0.9. If this clearance volume is 30 cm^3 then the stroke (in cm) and compression ratio will be

- A) 7 and 10 B) 8 and 12 C) 7.5 and 11 D) 7.5 and 12

42. When austenite steel is air cooled, the structure produced will be

- A) Martensite B) Fine pearlite
 C) Coarse pearlite D) Troosite

43. The cutting tool material required to sustain high temperature is

- A) High carbon steel alloys B) Composite of lead and steel
 C) Cermet D) Alloy of steel, zinc and tungsten

44. Match the following:-

	Cutting tool materials				Manufacturing methods			
a)	HSS				1. Casting			
b)	Stellite				2. Forging			
c)	Cemented carbide				3. Rolling			
d)	UCON				4. Powder metallurgy			
	a	b	c	d				
A)	3	1	4	2				
B)	2	4	2	3				
C)	3	4	2	1				
D)	2	1	4	3				

45. In orthogonal cutting, the depth of cut is halved and the feed rate is double. If the chip thickness ratio is unaffected with the changed cutting conditions, the actual chip thickness will be
A) Doubled B) Quadrupled C) Halved D) Unchanged
46. In metal cutting operation, the approximate ratio of heat distributed among chip, tool and work, in that order is
A) 80: 10: 10 B) 33: 33: 33 C) 20: 60: 10 D) 10: 10: 80
47. Dry and compressed air is used as cutting fluid for machining
A) Steel B) Aluminium C) Cast iron D) Brass
48. Which of the following attachments can be used on Centre lathe?
A) Grinding B) Milling C) Copying D) All of these
49. The process which squeezes metals into peaks and troughs with plastic deformation
A) Grooving B) Knurling C) Reaming D) None of these
50. Material removal in electrochemical machining is based on
A) Fick's law B) Faraday's laws
C) Kirchhoff's laws D) Ohm's law

x-x-x

Medical Physics(Ph.D.)

1. A body at high temperature T °K radiates heat at rate proportional to
 - A) T^4
 - B) T^{-4}
 - C) T
 - D) T^2
2. Attenuation coefficient of bone is 600 m^{-1} for x-rays of energy 20 keV and intensity of beam of x-rays is 20 Wm^{-2} , then intensity of beam after passing through a bone of 4 mm is
 - A) 3 Wm^{-2}
 - B) 2.5 Wm^{-2}
 - C) 2.0 Wm^{-2}
 - D) 1.8 Wm^{-2}
3. Incident rate is measured by
 - A) Case control study
 - B) Cohort study
 - C) Cross-sectional study
 - D) Intervention study
4. Systolic BP= $a + b(\text{age}) + c(\text{BMI})$ is an example of
 - A) Simple linear regression
 - B) Simple curvilinear regression
 - C) Multiple linear regression
 - D) Multiple curvilinear regression
5. One gram of a radioactive substance takes 50 seconds to lose 1 centigram. The half life period of the radioactive substance is
 - A) 57 minutes
 - B) 75 minutes
 - C) 61 minutes
 - D) 55 minutes
6. How many half-value layers are required to reduce a 100 R/minute exposure rate to 25 R/minute?
 - A) 1
 - B) 2
 - C) 4
 - D) 8
7. A person's heart is imaged in a diagnostic procedure. The source to film distance is 100 cm and the object to film distance is 80cm. How much the heart will be magnified on the film?
 - A) 2 times
 - B) 4 times
 - C) 6 times
 - D) 5 times
8. Initial activity of an I^{123} sample ($t_{1/2} = 13 \text{ h}$) of thyroid counts is 480 MBq. After 12 h, measured activity is 20 MBq. Assuming the volume of the blood is 6l, find biological Half-life.

- A) 3
 - B) 6
 - C) 9
 - D) 11
9. What are the frequencies of L band, X band and S band microwave?
- A) 1-2 GHz, 2-4 GHz and 8-12 GHz
 - B) 1-2 GHz, 8-12 GHz and 2-4 GHz
 - C) 8-12 GHz, 1-2 GHz and 2-4 GHz
 - D) 8-12 GHz, 2-4 GHz and 1-2 GHz
10. What does radial function represent in TG 43 protocol?
- A) The changes in dose rate with radial distance from the source.
 - B) The changes in dose rate with radial distance which takes into account inverse square function.
 - C) The changes in dose rate with radial distance which does not take into account inverse square function.
 - D) The changes in dose rate with radial distance which takes into account inverse square function and distribution of radioactive materials within the source.
11. Beam spoiler in TBI radiotherapy is
- A) A sheet of Lucite placed in large fields to reduce dose rate.
 - B) A sheet of Lucite placed in large fields to improve beam penetration.
 - C) A sheet of Lucite placed in large fields to reduce depth of d_{max} .
 - D) A sheet of Lucite placed in large fields to increase the skin dose.
12. How will the dose be calculated for extended SSD for electron beam radiotherapy?
- A) Using the virtual SSD
 - B) Using the effective SSD
 - C) Using inverse square law and virtual SSD
 - D) Using inverse square law and effective SSD
13. What are the advantages of green sensitive film over blue sensitive films?
- A) Green sensitive films are insensitive to blue dye.
 - B) Green sensitive films are well matched with the screen of $GdO_2S:Tb$ which emits whole 6 series whereas Blue sensitive film is not well matched with it.
 - C) There is no perfect matching screen film combination of blue sensitive film whereas perfect matching screen film combination is available in case of green sensitive film.
 - D) Blue sensitive films are sensitive to blue dye.
14. Point A according Classical Manchester is defined in Gynecological implants to be a point located
- A) 2 cm cephalad of the last end source of uterine tandem and 2 cm lateral to uterine tandem
 - B) 2 cm cephalad from the lateral fornix and 2 cm lateral to the uterine tandem
 - C) 2 cm cephalad of the external cervical os and 2 cm lateral to the uterine tandem
 - D) 2cm up from the flange and 2 cm lateral to the uterine tandem
15. For stereotactic radiosurgery treatment of AVM, the minimum imaging modalities requirements are

- A) DSA and MRI
- B) MRI and CT
- C) DSA, MRI and ultrasound
- D) DSA and ultrasound

16. Acceptable gradient index in Stereotactic radiosurgery using gamma knife for the determination of quality of treatment plan is
- A) the ratio of the volume of 20 % and 50 % isodose curves in the ranges from 1.5 -2.
 - B) the ratio of the volume of 25 % and 50 % isodose curves in the ranges from 2.5 -3.
 - C) the ratio of the volume of 10 % and 90 % isodose curves in ranges from 2.5 -5.
 - D) the ratio of the volume of 10 % and 90 % isodose curves in ranges from 1.5 -2.
17. The classified worker is defined according to AERB RPR- 2004 is
- A) Who is likely to receive an effective dose in excess of 1/10 of average annual dose limit.
 - B) Who is likely to receive an effective dose in excess of 1/5 of average annual dose limit.
 - C) Who is likely to receive an effective dose in excess of 1/10 of average annual dose limit.
 - D) Who is likely to receive an effective dose in excess of 3/10 of average annual dose limit.
18. Radiation damage is divided into (a) lethal damage, (b) sublethal damage and (c) potentially lethal damage (PLD). Which of the following statements is true?
- A) PLD will cause cell death under ordinary circumstances.
 - B) PLD cannot be repaired under ordinary circumstances.
 - C) The variation of post-irradiation conditions cannot enhance PLD repair.
 - D) Mitosis cannot be delayed by suboptimal growth conditions.
19. In comparing two 6 MV x-ray beams, both 100 cm² in total area but one having 10x10 cm² collimator setting and the other 5x20 cm², what can be said about the relative doses at d_{max}?
- A) The primary dose is higher for a 10x10 field.
 - B) The scatter dose is higher for a 10x10 field.
 - C) Both the primary and scatter doses are higher for a 10x10 field.
 - D) The doses for the two fields will be the same.
20. Which of the following is not refer to portal dosimetry using EPIDs
- A) Dose profile measurement
 - B) IMRT QA
 - C) Patient position verification
 - D) MLC alignment verification
21. When CT images are used for radiotherapy planning, Hounsfield numbers must be converted to electron densities for use by the dose calculation algorithms. The relationship between Hounsfield number and electron density is approximately linear for most tissues except
- A) Lung
 - B) Air cavities
 - C) Muscle
 - D) Bone

22. The skin dose for a 6 MeV electron beam is lower than for a 15 MeV electron beam because for the 6 MeV beam there is
- A) More range straggling
 - B) Less range straggling
 - C) More x-ray contamination
 - D) Lower linear energy transfer (LET)
23. Regarding single-fraction total body irradiation (TBI)
- A) The dose rate should be relatively high (> 1 Gy/min) to keep the treatment time as short as possible.
 - B) The dose rate should be low (<0.2 Gy/min) to minimize the side effects.
 - C) If the treatment is delivered from two lateral fields, electron boost fields are sometimes used for the chest wall.
 - D) The dose should be at least 20 Gy.
24. A cone-beam scan is taken to set up a cranium in an image-guided SRS procedure. The IGRT software is capable of calculating both 3D and 6D couch/corrections. The couch being used for treatment, however, is only capable of implementing 3D corrections. The calculated corrections for 3D and 6D are different. What is the best course of action?
- A) Report a bug in the software.
 - B) Use the 6D correction factors.
 - C) Use the 3D correction factors.
 - D) Use the average of the two sets of translations.
25. What is the cause of tongue-and-groove effect for MLC-based IMRT?
- A) Leaves that are moving too slowly
 - B) Leaves that are out of calibration
 - C) Adjacent leaves that extend into the field by very different amounts
 - D) Opposing leaves that are closed, but are not under the jaw
26. Regarding single-fraction total body irradiation (TBI)
- A) The dose rate should be relatively high (> 1 Gy/min) to keep the treatment time as short as possible.
 - B) The dose rate should be low (<0.2 Gy/min) to minimize the side effects.
 - C) If the treatment is delivered from two lateral fields, electron boost fields are sometimes used for the chest wall.
 - D) The dose should be at least 20 Gy.
27. Which of the following is used for IMRT plan evaluation?
- A) Dose prescription will be done by the isodose curve which covers the 95% volume of Planning target volume.
 - B) Dose prescription will be done by the normalization point on ICRU reference points.
 - C) Dose prescription will be done by 100% normalization to the average dose of Planning Target Volume and 95% of prescribed dose should enclosed the near maximum target volume i.e. 95% PTV and volume of PTV for near maximum dose i.e. 107% of prescribed dose should be lesser than 2%.
 - D) Dose prescription will be done by 100% normalization to the average dose of Planning Target Volume and 95% of prescribed dose should enclosed the near maximum target

volume i.e. 98% PTV and volume of PTV for near maximum dose i.e. 107% of prescribed dose should be lesser than 2%.

28. Chemical shift artifacts are caused by differences in the
 - A) T1 relaxation time
 - B) T2 relaxation time
 - C) Spin density
 - D) Larmor frequency**
29. The Q factor of an ultrasound transducer describes the
 - A) Crystal resonance frequency
 - B) Fresnel zone length
 - C) frequency response of the crystal
 - D) FWHM value of the beam intensity
30. Which statement is *not* true of electromagnetic radiation?
 - A) It travels at the speed of light.
 - B) It exhibits particulate properties.
 - C) Photon energy is proportional to its frequency.
 - D) Wavelength is proportional to the frequency.
31. The average photon energy of an x-ray beam cannot be changed by
 - A) Tube current (mA)
 - B) Beam filtration
 - C) Tube voltage
 - D) Voltage waveform
32. Following absorption of a single 30 keV photon in a patient
 - A) Temperature rises significantly (more than 1°C)
 - B) A number of ionization events occur
 - C) Several scatter photons emerge
 - D) Internal conversion electrons are emitted
33. The average energy of K-shell characteristic x-rays are not
 - A) About 18 keV for molybdenum anodes
 - B) Dependent on the shell structure of the target atom
 - C) Independent on x-ray filtration
 - D) Independent of atomic number (Z)
34. Entrance skin dose for an anterior-posterior abdominal x-ray examinations is typically
 - A) Below 1 mGy (100 mrad)
 - B) 1 mGy (100 mrad)
 - C) 3 mGy (300 mrad)
 - D) 10 mGy (1 rad)
35. Which of the following has the shortest T1 value?
 - A) Fat
 - B) Liver
 - C) White matter

- D) Cerebrospinal fluid
36. A material with an attenuation 5% greater than that of water has a Hounsfield unit value of
A) -50
B) -5
C) +5
D) +50
37. If an average of 10,000 photons are detected per mm^2 , the chance of detecting between 9,700 and 10,300 counts in any exposed mm^2 is
A) 67% B) 90% C) 95% D) 99%
38. A Geiger-Muller detector would be best employed to
A) detect low-level $^{99\text{m}}\text{Tc}$ contamination
B) measure the output of an x-ray tube
C) monitor patient exposures
D) measure x-ray leakage exposure
39. A constant potential generator operated at 100 kV and 1,000 mA for 0.1 second deposits
A) 1,000 heat units
B) 1,350 heat units
C) 10,000 heat units
D) 13,500 heat units
40. The number of electrons accelerated across an x-ray tube is determined by
A) Anode speed
B) Focal spot size
C) Filament current
D) X-ray tube voltage
41. When heated, TLDs emit
A) X-rays
B) Photoelectrons
C) Characteristic x-rays
D) Light
42. Patient doses in fluoroscopy can exceed 100 mGy/minute (10 R/minute) if
A) High kilovolt peak values are used
B) Exposure time does not exceed 5 minutes
C) Visible/audible indicators are activated
D) Contrast agents have been administered
43. The skin dose for a chest x-ray examinations is
A) Less than 0.05 mGy (3 mrad)
B) About 0.05 mGy (3 mrad)
C) About 0.15 mGy (15 mrad)
D) About 0.5 mGy (50 mrad)

44. Which of the following is *not* a quality control test performed on a gamma camera?
A) Field uniformity
B) ^{99}Mo breakthrough
C) Extrinsic flood
D) Spatial resolution
45. According to the ALARA concept, annual doses to x-ray technologists should be
A) Zero
B) 5 mSv (500 mrem)
C) 50 mSv (5 rem)
D) As low as possible
46. Which of the following are types of stochastic effects?
A) Skin erythema B) Infertility C) Breast cancer D) Cataracts
47. The photoelectric absorption cross-section for alpha-ray is proportion to
A) Z^2
B) $1/Z^2$
C) Z^5
D) Z^4
48. Name the accelerator which cannot accelerate protons
A) Betatron
B) Cyclotron
C) Synchrotron
D) Cockcrof Walton accelerator
49. Which of the following statement is considered a multivariate model?
A) Height and weight vary together
B) Height varies with age, weight, and sex
C) Height and weight vary with age and sex
D) None of the above
50. The LD_{50/60} dose for humans is approximately equal to
A) 1 Gy
B) 4 Gy
C) 10 Gy
D) 12 Gy